



笔记本维修资料 <http://shop36509371.taobao.com>
QQ:52643956

DESIGNER	<OrgAddr1>	
CHECKED	<OrgAddr2>	
APPROVED	<OrgAddr3>	
CLASS	<OrgAddr4>	
THIS DOCUMENT IS THE PROPERTY OF LENOVO. ITS USE IS AUTHORIZED ONLY FOR RESPONDING TO A REQUEST FOR QUOTATION OR FOR THE PERFORMANCE OF WORK FOR LENOVO. ALL QUESTIONS MUST BE REFERRED TO THE LENOVO PURCHASING DEPARTMENT.		Part No. 42X7359
		EC No. L52888
		TITLE: Kodachi2 Ver: PDV
		BLOCK DIAGRAM
LENOVO CONFIDENTIAL		sheet 1 of 102 Tuesday, October 30, 2007

BLANK PAGE

笔记本维修资料 <http://shop36609371.taobao.com>

QQ:52643956

DESIGNER	<OrgAddr1>	
CHECKED	<OrgAddr2>	
APPROVED	<OrgAddr3>	Part No . 42X7359
CLASS	<OrgAddr4>	EC No . L52888
<small>THIS DOCUMENT IS THE PROPERTY OF LENOVO. ITS USE IS AUTHORIZED ONLY FOR RESPONDING TO A REQUEST FOR QUOTATION OR FOR THE PERFORMANCE OF WORK FOR LENOVO. ALL QUESTIONS MUST BE REFERRED TO THE LENOVO PURCHASING DEPARTMENT.</small>		TITLE: Kodachi2 Ver: PDV
		CPU(2/3)
LENOVO CONFIDENTIAL		sheet 2 of 102 Tuesday, October 30, 2007

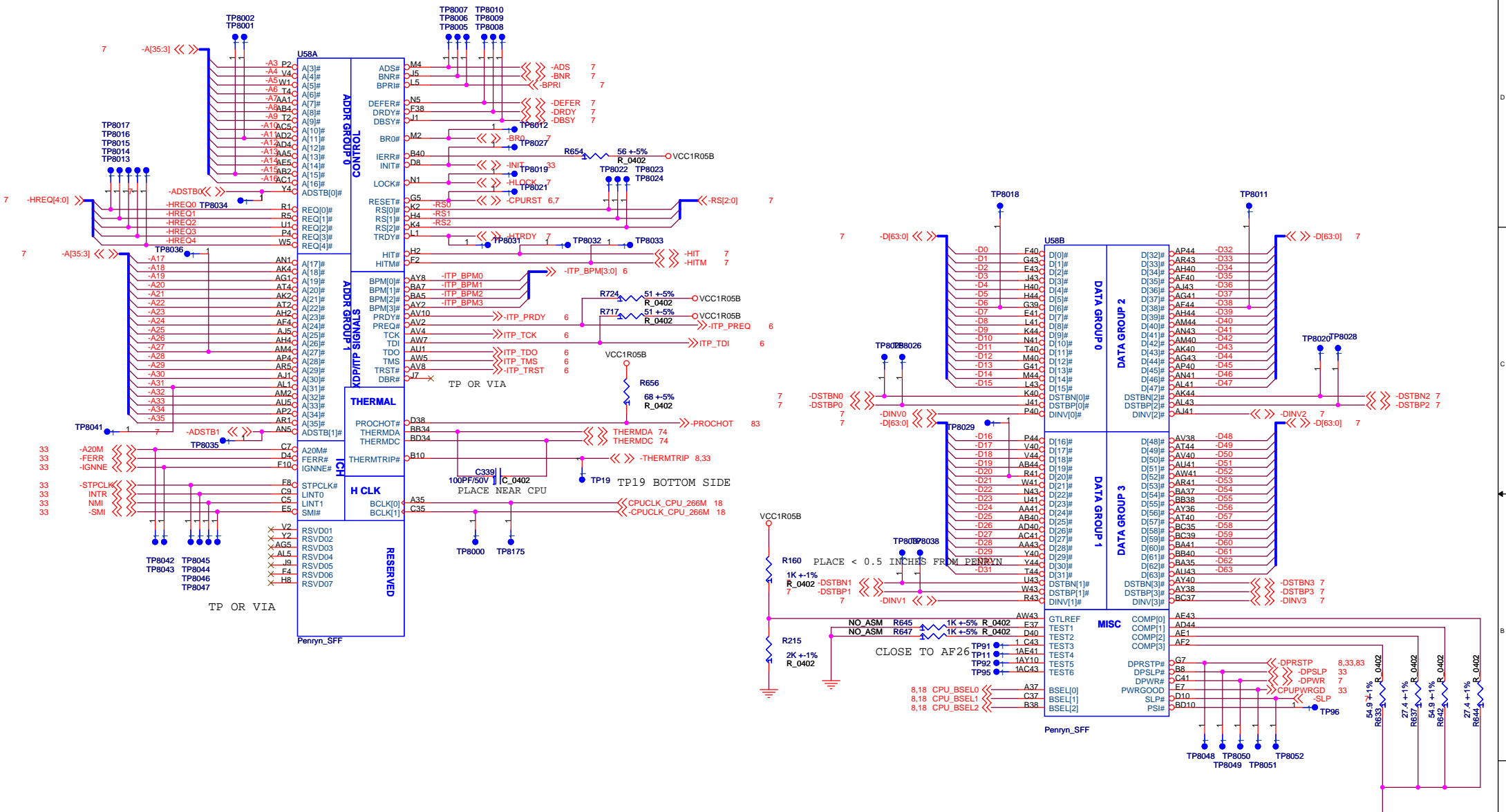

COM0/2: Z0=27.4 OHM TRACE<0.5"
 COM1/3: Z0=55 OHM TRACE<0.5"

笔记本维修资料 <http://shop36609371.taobao.com>

QQ:52643956

DESIGNER	<OrgAddr1>	
CHECKED	<OrgAddr2>	
APPROVED	<OrgAddr3>	Part No. 42X7359
CLASS	<OrgAddr4>	Ec No. L52888
<small>THIS DOCUMENT IS THE PROPERTY OF LENOVO. ITS USE IS AUTHORIZED ONLY FOR RESPONDING TO A REQUEST FOR QUOTATION OR FOR THE PERFORMANCE OF WORK FOR LENOVO. ALL QUESTIONS MUST BE REFERRED TO THE LENOVO PURCHASING DEPARTMENT.</small>		
		TITLE: Kodach2 Ver: PDV
		CPU(1/3)
LENOVO CONFIDENTIAL		sheet 3 of 102 Tuesday, October 30, 2007

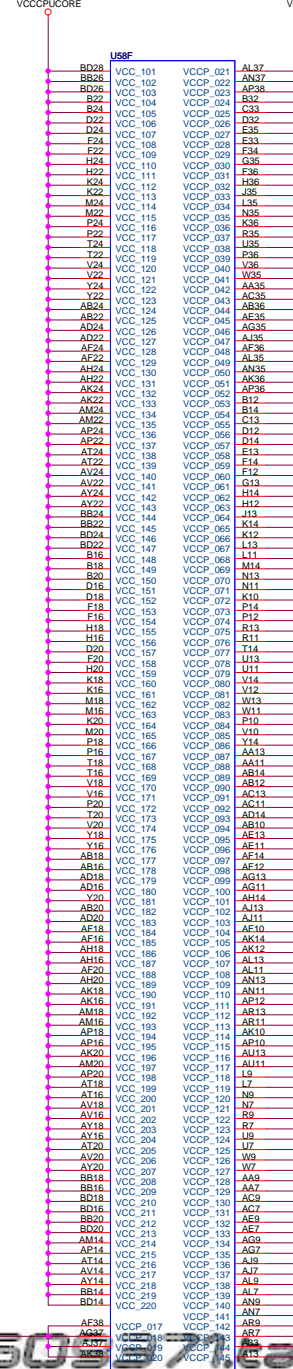
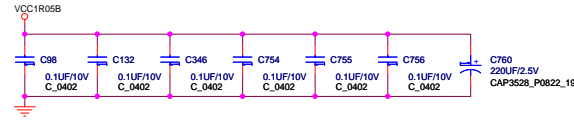
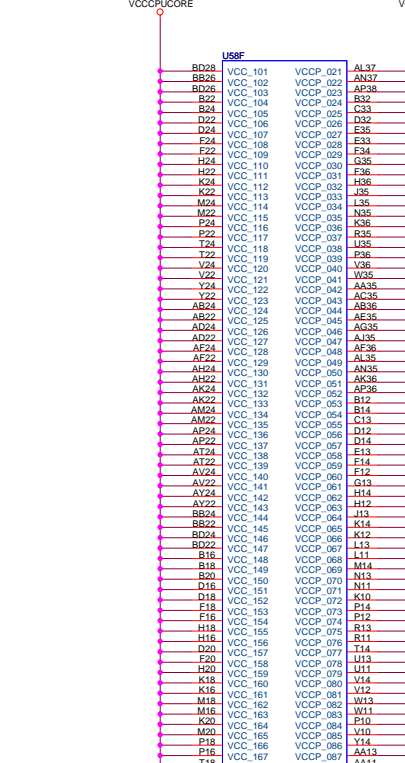
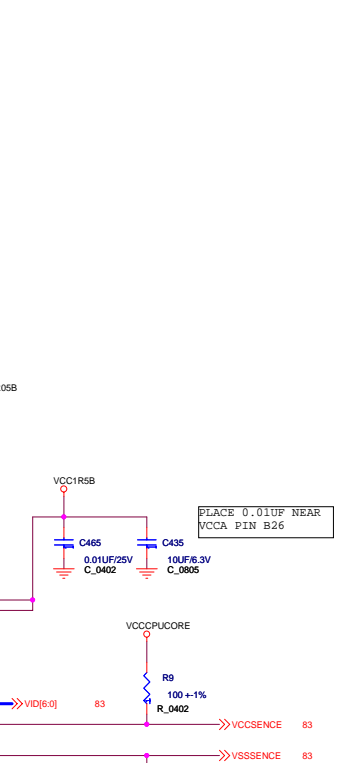
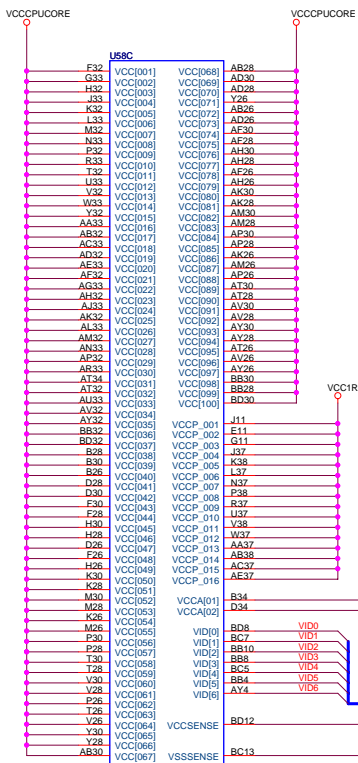

笔记本维修资料 <http://shop36609771.taobao.com>
 QQ:52643956

DESIGNER	<OrgAddr1>	lenovo	
CHECKED	<OrgAddr2>	Part No.	42X7359
APPROVED	<OrgAddr3>	EC No.	L52888
CLASS	<OrgAddr4>	TITLE:	Kodach2 Ver: PDV
THIS DOCUMENT IS THE PROPERTY OF LENOVO. ITS USE IS AUTHORIZED ONLY FOR REPAIRING TO A REQUEST FOR QUOTATION OR FOR THE PERFORMANCE OF WORK FOR LENOVO. ALL QUESTIONS MUST BE REFERRED TO THE LENOVO PURCHASING DEPARTMENT.			
		CPU(2/3)	
sheet 4 of 102		Tuesday, October 30, 2007	
LENOVO CONFIDENTIAL			

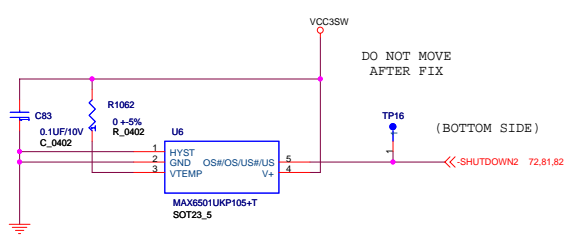
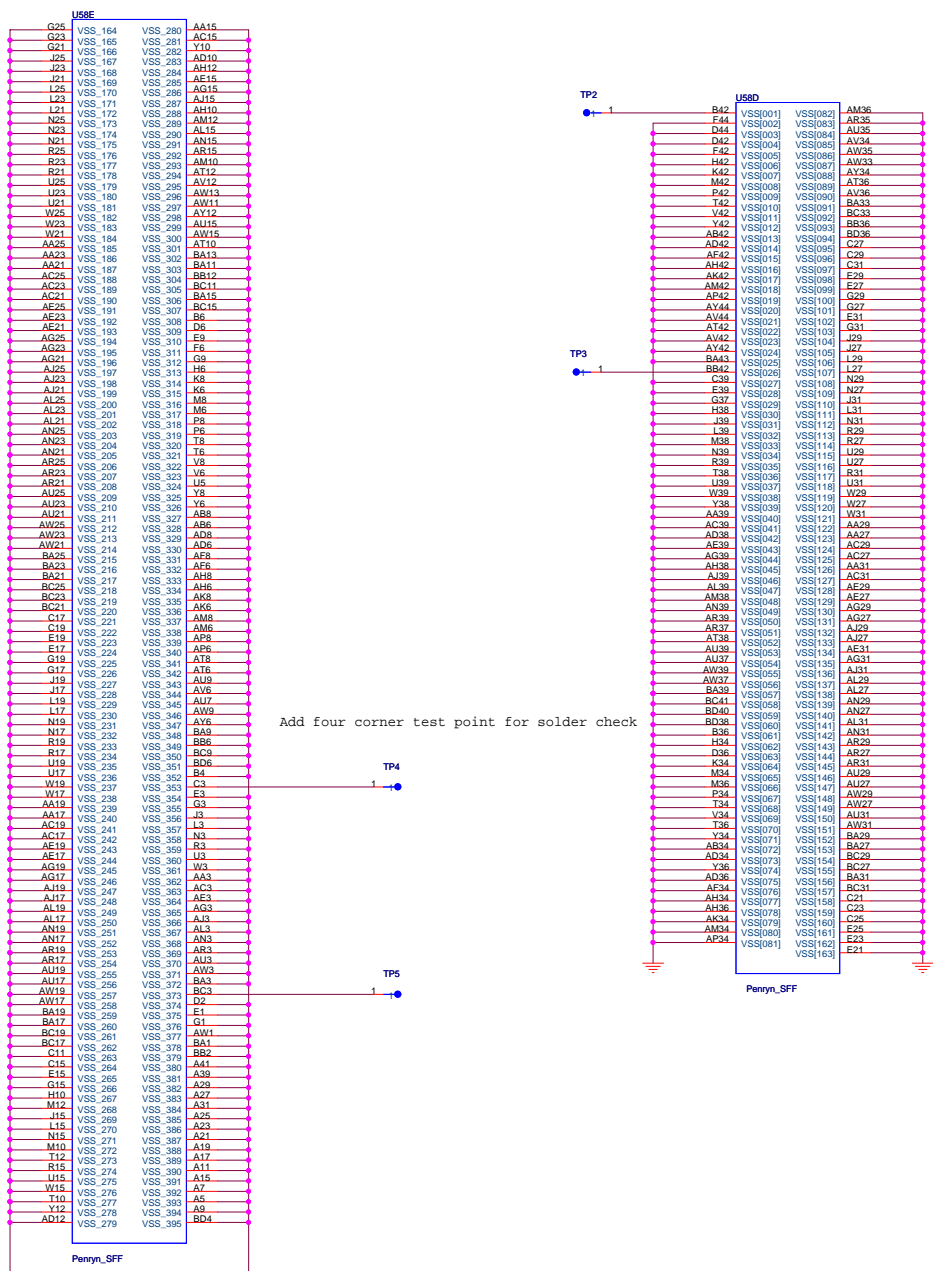

TABLE

U1	R1061
NS LM26	NOASM
MAXIM MAX6519	NOASM
MAXIM MAX6501	ASM
ADI ADT6501	ASM

笔记本维修资料 <http://shop36609271.taobao.com>
 QQ:5264956

DESIGNER	<OrgAddr1>	lenovo
CHECKED	<OrgAddr2>	
APPROVED	<OrgAddr3>	Part No. 42X7359
CLASS	<OrgAddr4>	EC No. L52888
THIS DOCUMENT IS THE PROPERTY OF LENOVO. ITS USE IS RESTRICTED ONLY FOR REPAIRING TO A REQUEST FOR QUOTATION OR FOR THE PERFORMANCE OF WORK FOR LENOVO. ALL OTHERS MUST BE REFERRED TO THE LENOVO PURCHASING DEPARTMENT.		
TITLE: Kodach2 Ver: PDV		CPU(3/3)
sheet	5 of 102	
Tuesday, October 30, 2007		

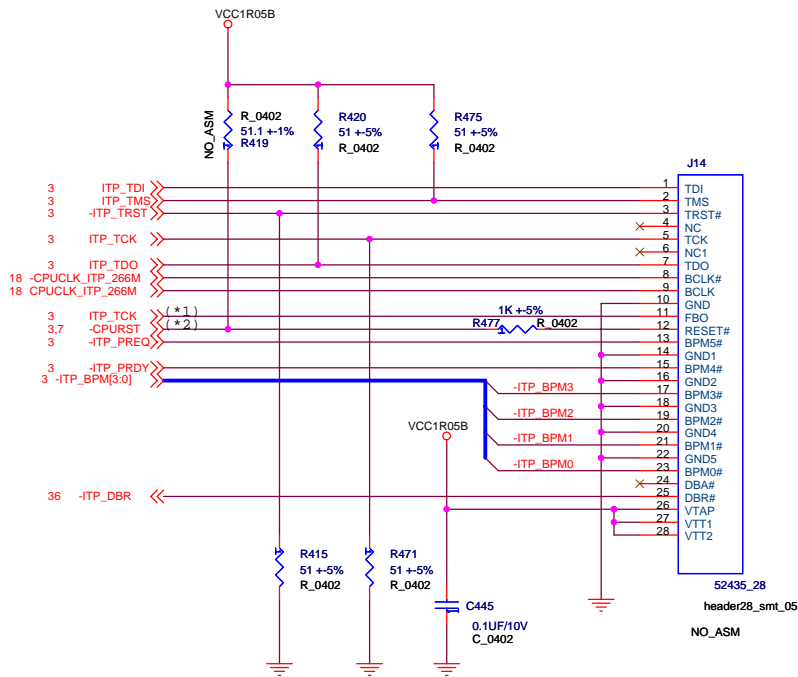

TABLE

REF DES	FOR ITP700FLEX	FOR ITP-->XDP
J14	NO_ASM---->ASM	NO_ASM---->ASM
C445	ASM(NO CHANGE)	ASM(NO CHANGE)
R717	ASM---->150 5% ASM	ASM(NO CHANGE)
R477	ASM---->22.6 1% ASM	ASM(NO CHANGE)
R415	ASM(NO CHANGE)	ASM(NO CHANGE)
R419	NO_ASM---->ASM	NO_ASM(NO CHANGE)
R420	ASM(NO CHANGE)	ASM(NO CHANGE)
R471	ASM---->27.4 1% ASM	ASM(NO CHANGE)
R475	ASM---->39.2 1% ASM	ASM(NO CHANGE)

NOTES: C445 and R447:"ASM" before SIT, "NO_ASM" from SIT.
J14 "ASM" for PRE_DV only

(*1) TCK SIGNAL IS BRANCHED AT Penryn PIN
(*2) -CPURST SIGNAL IS BRANCHED AT Cantiga PIN

笔记本维修资料 <http://shop36609371.taobao.com>

QQ:52643956

DESIGNER	<OrgAddr1>	lenovo 联想
CHECKED	<OrgAddr2>	
APPROVED	<OrgAddr3>	Part No. 42X7359
CLASS	<OrgAddr4>	EC No. L52888
THIS DOCUMENT IS THE PROPERTY OF LENOVO. ITS USE IS AUTHORIZED ONLY FOR RESPONDING TO A REQUEST FOR QUOTATION OR FOR THE PERFORMANCE OF WORK FOR LENOVO. ALL QUESTIONS MUST BE REFERRED TO THE LENOVO PURCHASING DEPARTMENT.		
TITLE: Kodachi2 Ver: PDV		ITP CONNECTOR
LENOVO CONFIDENTIAL		sheet 6 of 102 Tuesday, October 30, 2007

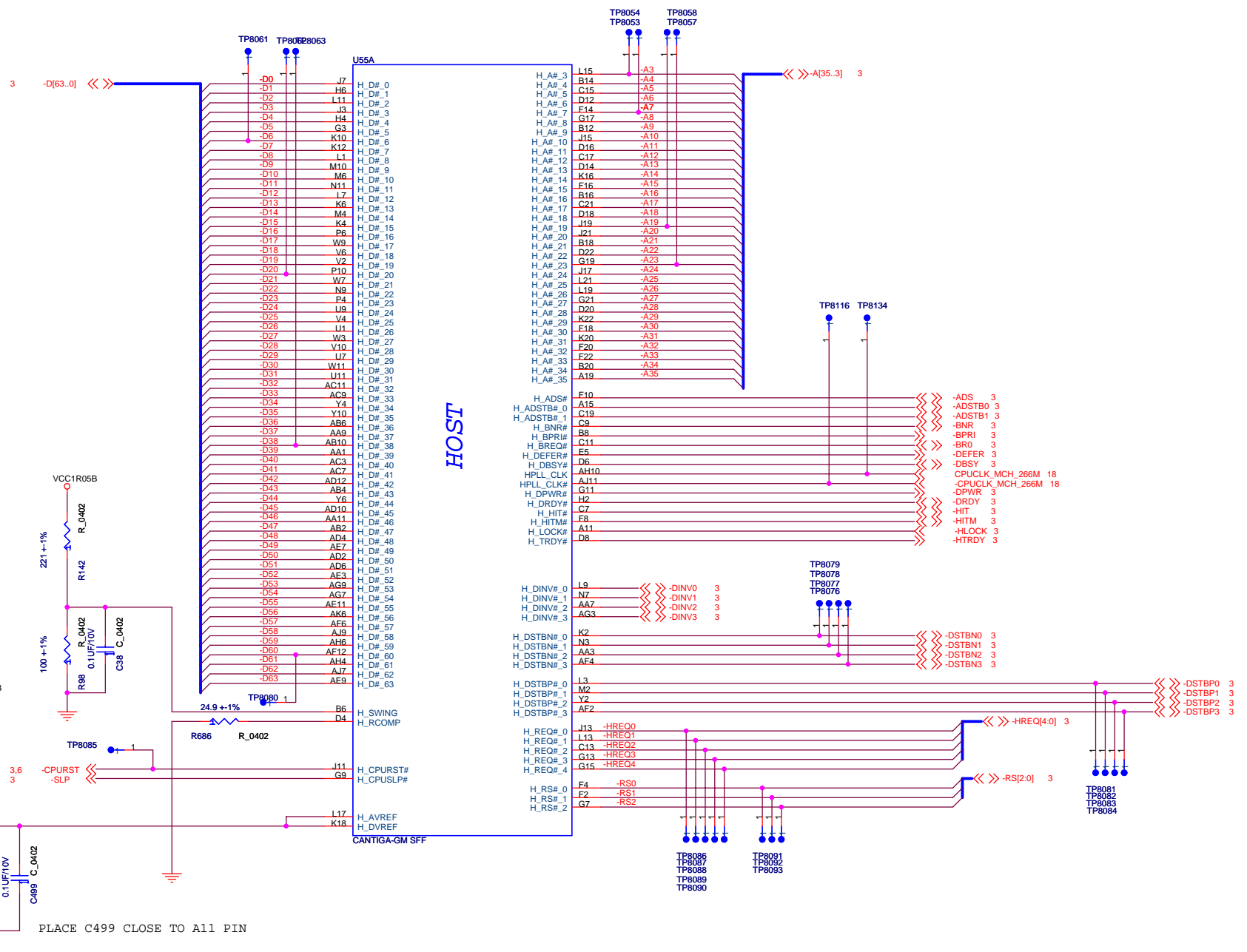

PLACE C499 CLOSE TO ALL PIN

笔记本维修资料 <http://shop36609371.taobao.com>

QQ:52643956

DESIGNER	<OrgAddr1>	
CHECKED	<OrgAddr2>	
APPROVED	<OrgAddr3>	Part No. 42X7359
CLASS	<OrgAddr4>	EC No. L52888
<small>THIS DOCUMENT IS THE PROPERTY OF LENOVO. ITS USE IS AUTHORIZED ONLY FOR RESPONDING TO A REQUEST FOR QUOTATION OR FOR THE PERFORMANCE OF WORK FOR LENOVO. ALL QUESTIONS MUST BE REFERRED TO THE LENOVO PURCHASING DEPARTMENT.</small>		TITLE: Kodachi2 Ver: PDV
		CANTIGA(1/8) : HOST I/F
LENOVO CONFIDENTIAL		sheet 7 of 102 Tuesday, October 30, 2007

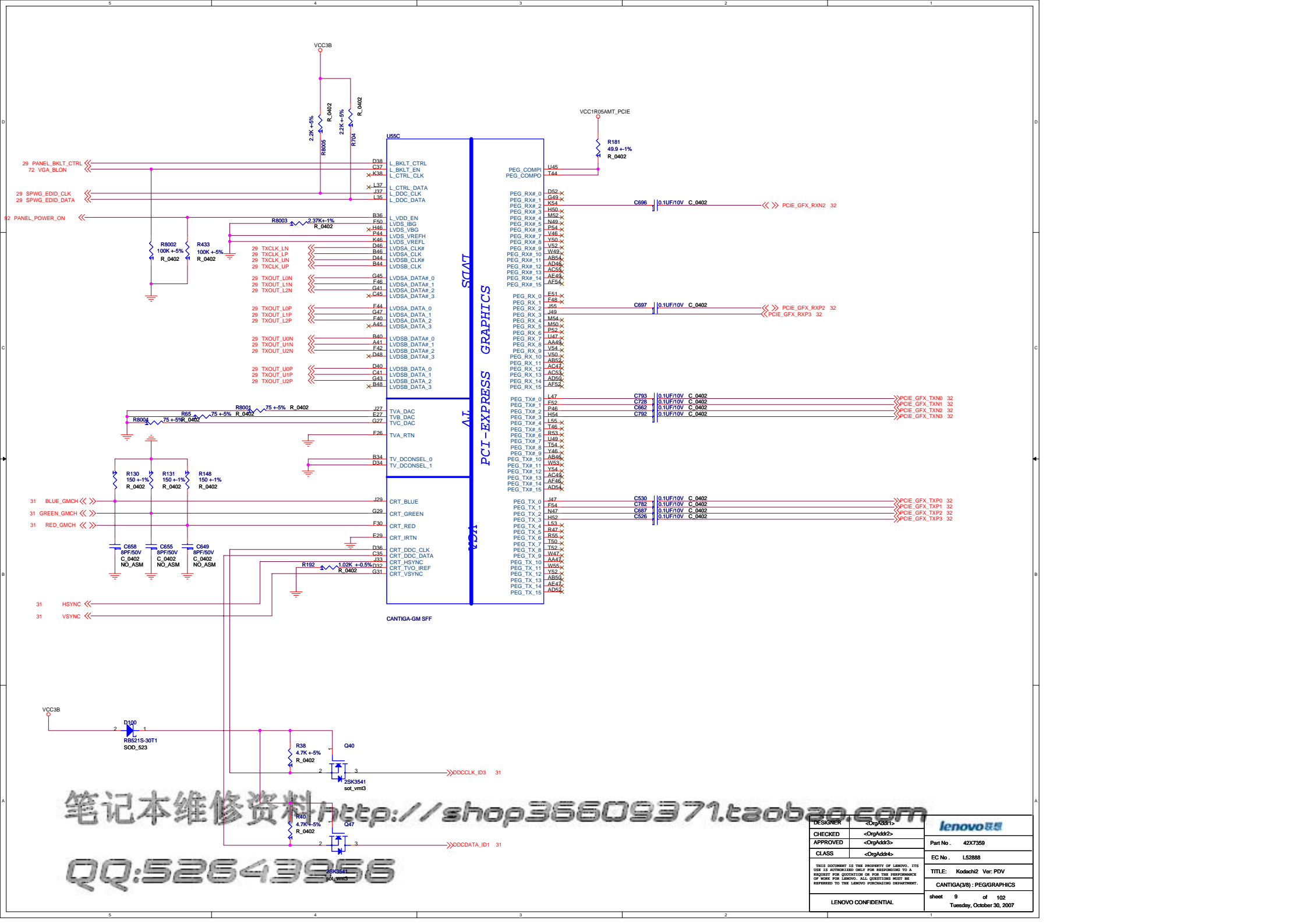

笔记本维修资料 <http://shop36609371.taobao.com>
 QQ:52643956

DESIGNER	<OrgAddr1>	
CHECKED	<OrgAddr2>	
APPROVED	<OrgAddr3>	
CLASS	<OrgAddr4>	
<small>THIS DOCUMENT IS THE PROPERTY OF LENOVO. ITS USE IS RESTRICTED ONLY FOR REPAIRING TO A REQUEST FOR QUOTATION OR FOR THE PERFORMANCE OF WORK FOR LENOVO. ALL QUESTIONS MUST BE REFERRED TO THE LENOVO PURCHASING DEPARTMENT.</small>		Part No. 42X7359 EC No. L52888 TITLE: KodaCh2 Ver: PDV CANTIGA(3/8) : PEG/GRAPHICS sheet 9 of 102 Tuesday, October 30, 2007
LENOVO CONFIDENTIAL		

15 M_A_DQ[63.0]

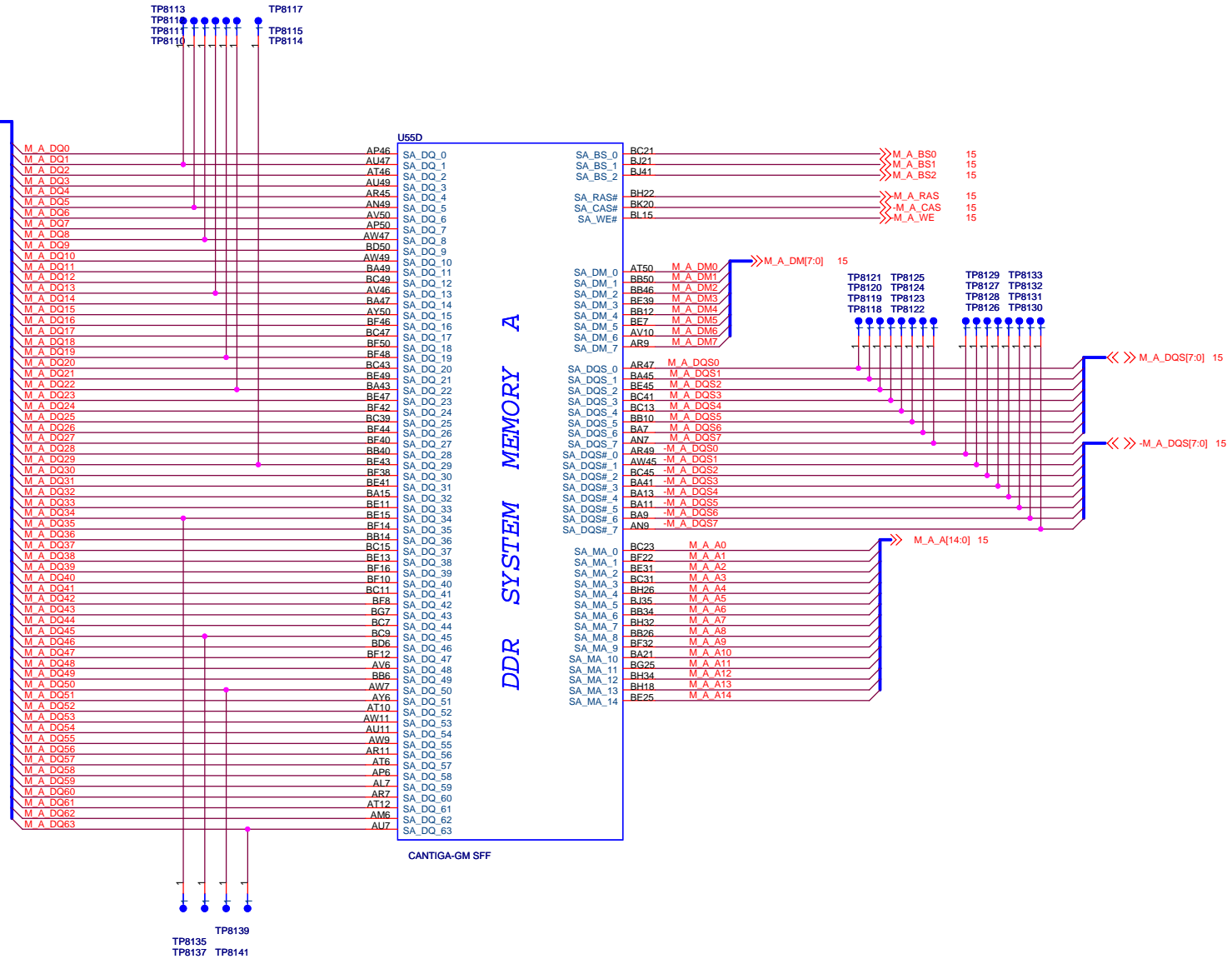

笔记本维修资料 <http://shop36609371.taobao.com>
 QQ:52643956

DESIGNER	<OrgAddr1>	lenovo 联想
CHECKED	<OrgAddr2>	
APPROVED	<OrgAddr3>	Part No. 42X7359
CLASS	<OrgAddr4>	EC No. L52888
THIS DOCUMENT IS THE PROPERTY OF LENOVO. ITS USE IS AUTHORIZED ONLY FOR RESPONDING TO A REQUEST FOR QUOTATION OR FOR THE PERFORMANCE OF WORK FOR LENOVO. ALL QUESTIONS MUST BE REFERRED TO THE LENOVO PURCHASING DEPARTMENT.		TITLE: Kodachi2 Ver: PDV
LENOVO CONFIDENTIAL		CANTIGA(4/8) : DDR3 CHANNEL-A
		sheet 10 of 102 Tuesday, October 30, 2007

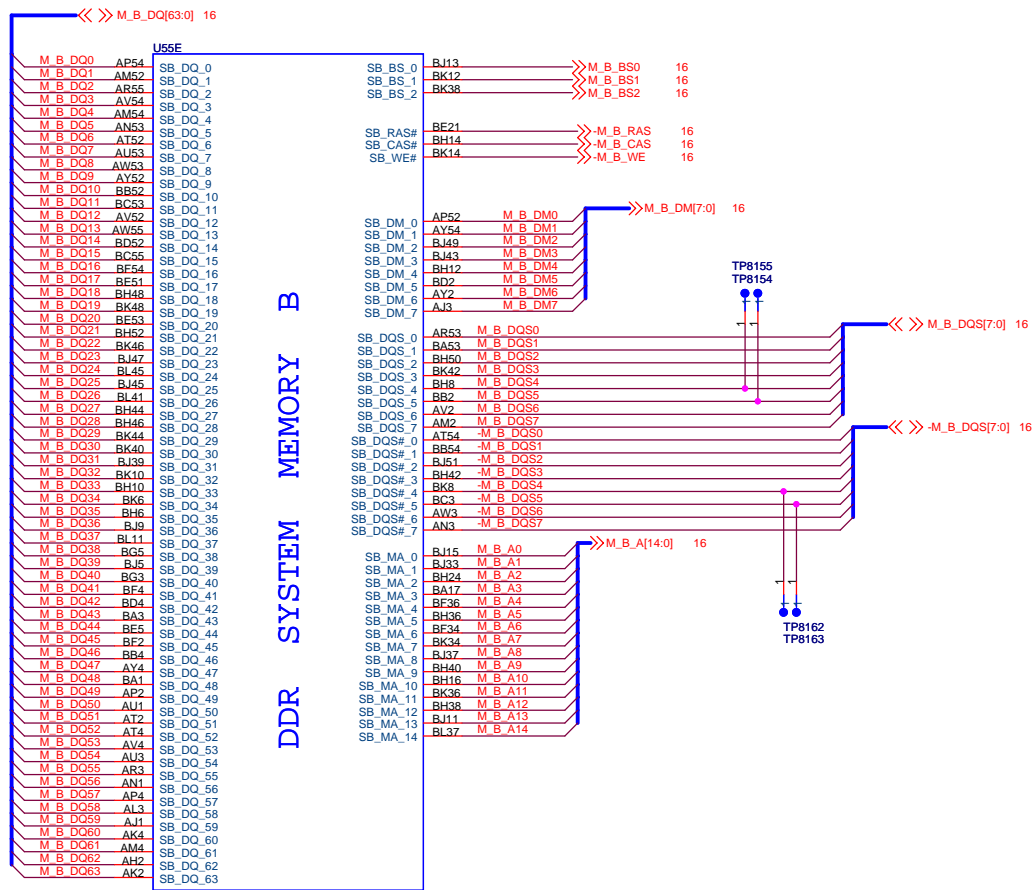

CANTIGA-GM SFF

笔记本维修资料 <http://shop36609371.taobao.com>

QQ:52643956

DESIGNER	<OrgAddr1>	
CHECKED	<OrgAddr2>	
APPROVED	<OrgAddr3>	
CLASS	<OrgAddr4>	Part No. 42X7359
<small>THIS DOCUMENT IS THE PROPERTY OF LENOVO. ITS USE IS AUTHORIZED ONLY FOR RESPONDING TO A REQUEST FOR QUOTATION OR FOR THE PERFORMANCE OF WORK FOR LENOVO. ALL QUESTIONS MUST BE REFERRED TO THE LENOVO PURCHASING DEPARTMENT.</small>		EC No. L52888
LENOVO CONFIDENTIAL		TITLE: Kodachi2 Ver: PDV CANTIGA(5/8) : DDR3 CHANNEL-B sheet 11 of 102 Tuesday, October 30, 2007

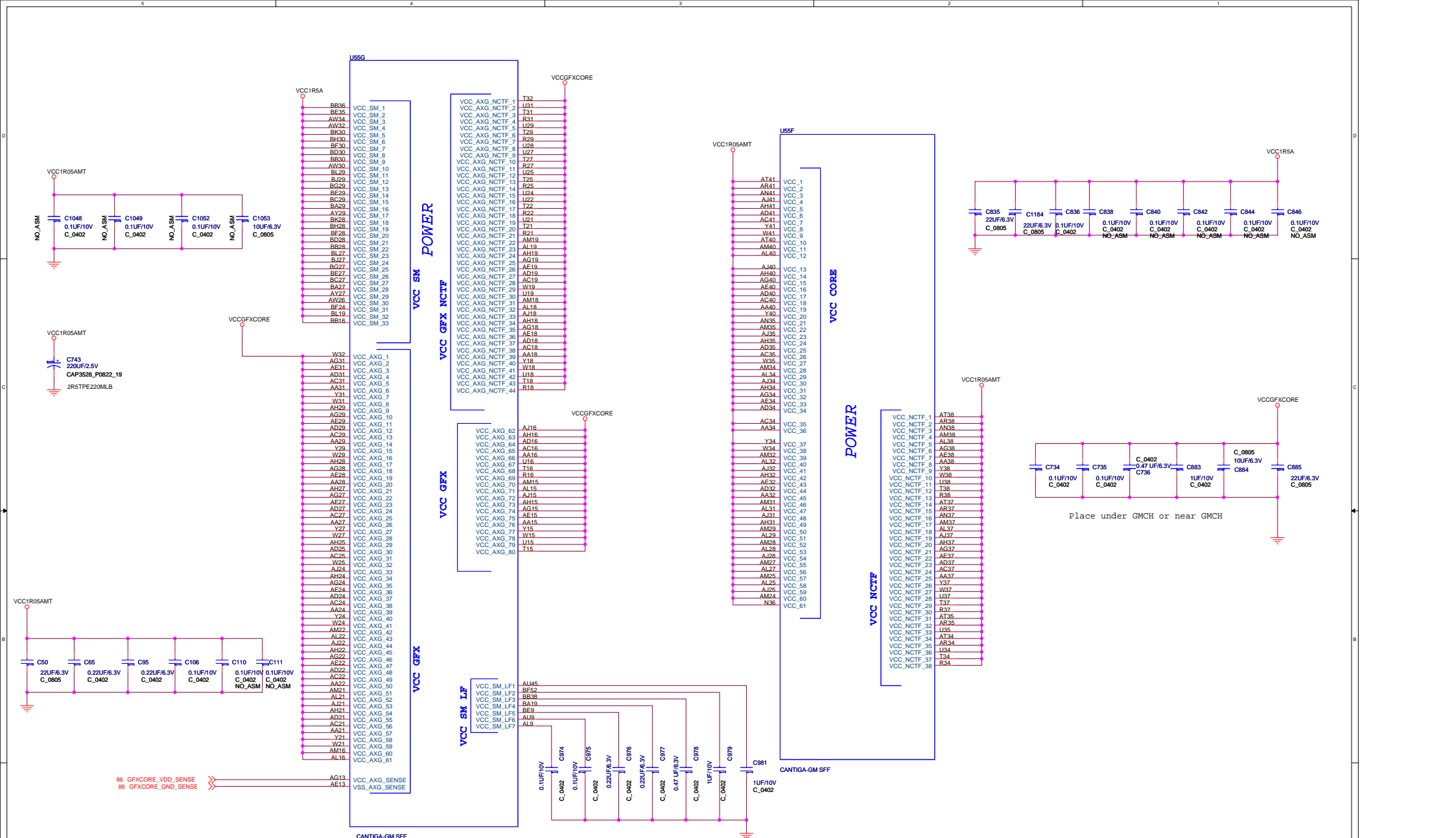

笔记本维修资料 <http://shop36609371.taobao.com>
 QQ:52643956

DESIGNER	<OrgAddr1>	lenovo
CHECKED	<OrgAddr2>	
APPROVED	<OrgAddr3>	Part No. 42X7359
CLASS	<OrgAddr4>	EC No. L52888
<small>THIS DOCUMENT IS THE PROPERTY OF LENOVO. ITS USE IS AUTHORIZED ONLY FOR REPAIRING TO A REQUEST FOR QUOTATION OR FOR THE PERFORMANCE OF WORK FOR LENOVO. ALL QUESTIONS MUST BE REFERRED TO THE LENOVO PURCHASING DEPARTMENT.</small>		
TITLE: CANTIGA(6)8 : POWER		
sheet 12 of 102		
<small>Tuesday, October 30, 2007</small> LENOVO CONFIDENTIAL		

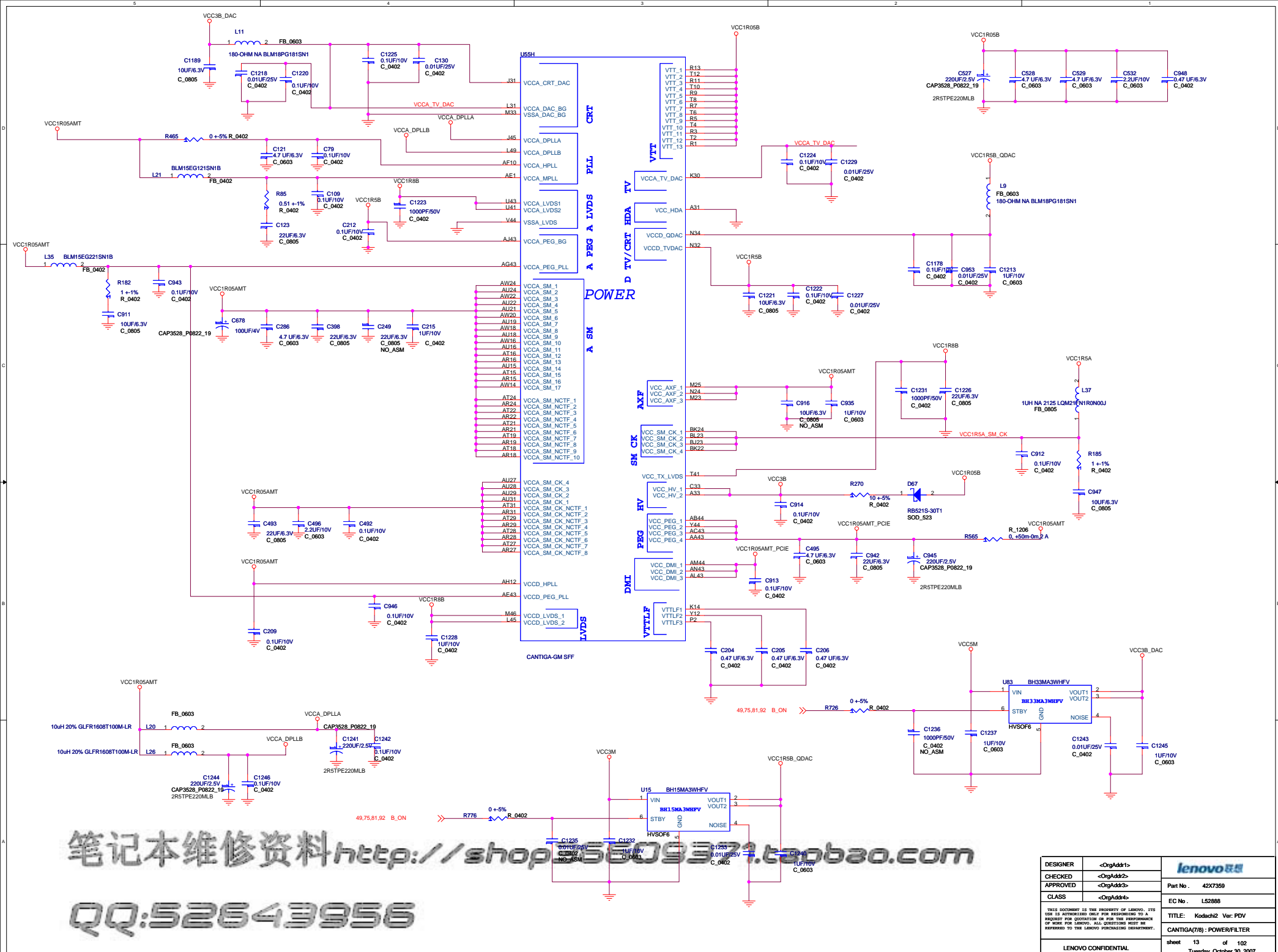

笔记本维修资料 <http://shop5609371.taobao.com>
 QQ:52643956

DESIGNER	<OrgAddr1>	 Part No. 42X7359 EC No. L52888 TITLE: Kodach2 Ver: PDV CANTIGA(7)B: POWER/FILTER sheet 13 of 102 Tuesday, October 30, 2007
CHECKED	<OrgAddr2>	
APPROVED	<OrgAddr3>	
CLASS	<OrgAddr4>	
THIS DOCUMENT IS THE PROPERTY OF LENOVO. ITS USE IS AUTHORIZED ONLY FOR REPAIRING TO A REQUEST FOR QUOTATION OR FOR THE PERFORMANCE OF WORK FOR LENOVO. ALL QUESTIONS MUST BE REFERRED TO THE LENOVO PURCHASING DEPARTMENT. LENOVO CONFIDENTIAL		

U551

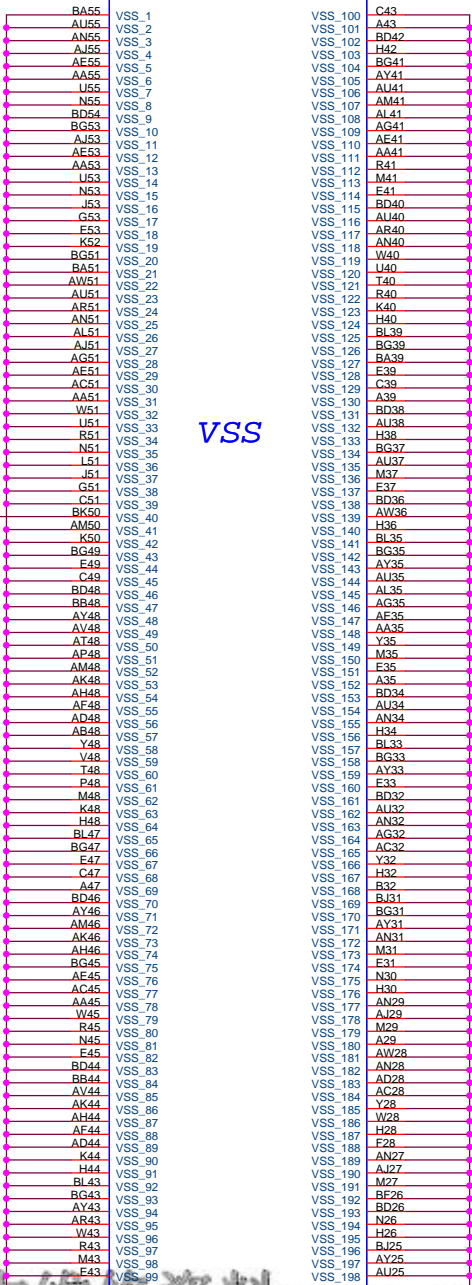

VSS

U55J

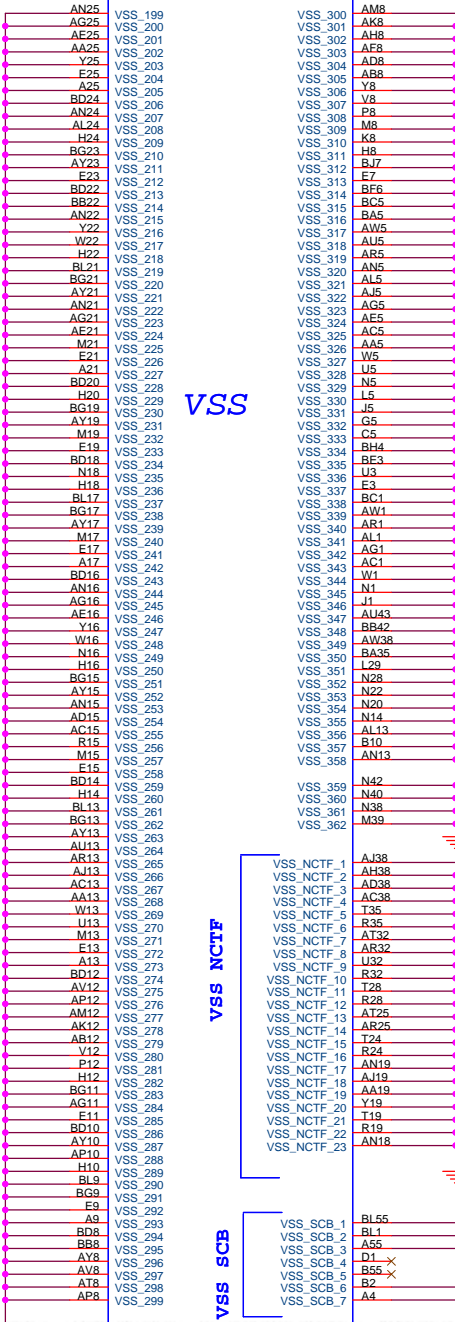

VSS

VSS NCTF

VSS SCB

Add four corner test point for solder check

MCH_SOLDER_SW 72

MCH_SOLDER_NW 72

笔记本维修资料 <http://shop35609371.taobao.com>

QQ:52643956

DESIGNER	<OrgAddr1>	lenovo联想
CHECKED	<OrgAddr2>	
APPROVED	<OrgAddr3>	Part No. 42X7359
CLASS	<OrgAddr4>	Ec No. L52888
THIS DOCUMENT IS THE PROPERTY OF LENOVO. ITS USE IS AUTHORIZED ONLY FOR RESPONDING TO A REQUEST FOR QUOTATION OR FOR THE PERFORMANCE OF WORK FOR LENOVO. ALL QUESTIONS MUST BE REFERRED TO THE LENOVO PURCHASING DEPARTMENT.		
TITLE: Kodach2 Ver: PDV		
CANTIGA(8/8) : GND		
sheet 14 of 102		
Tuesdays, October 30, 2007		
LENOVO CONFIDENTIAL		

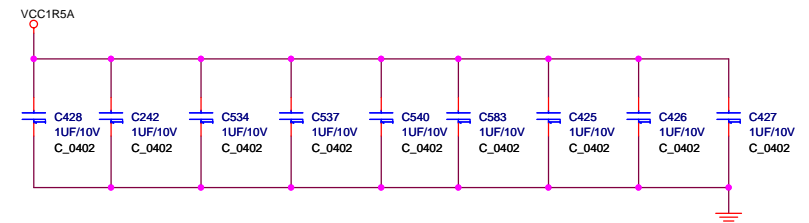
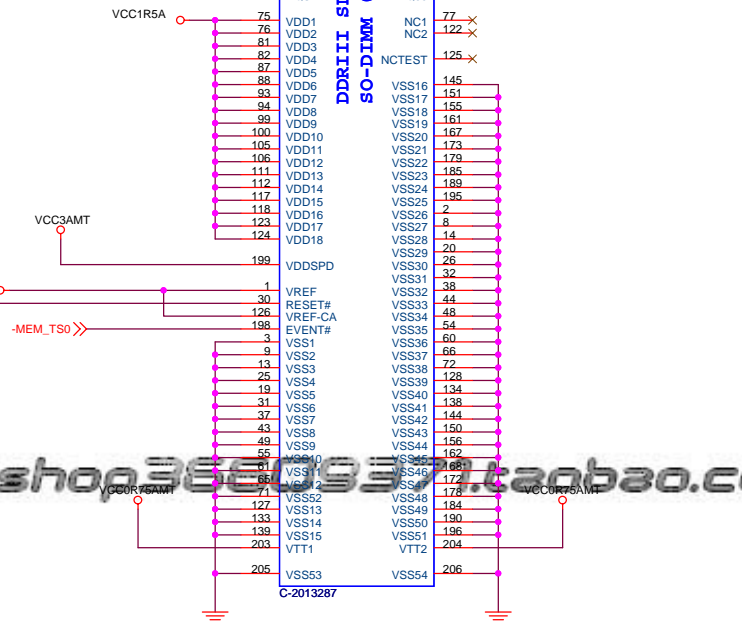
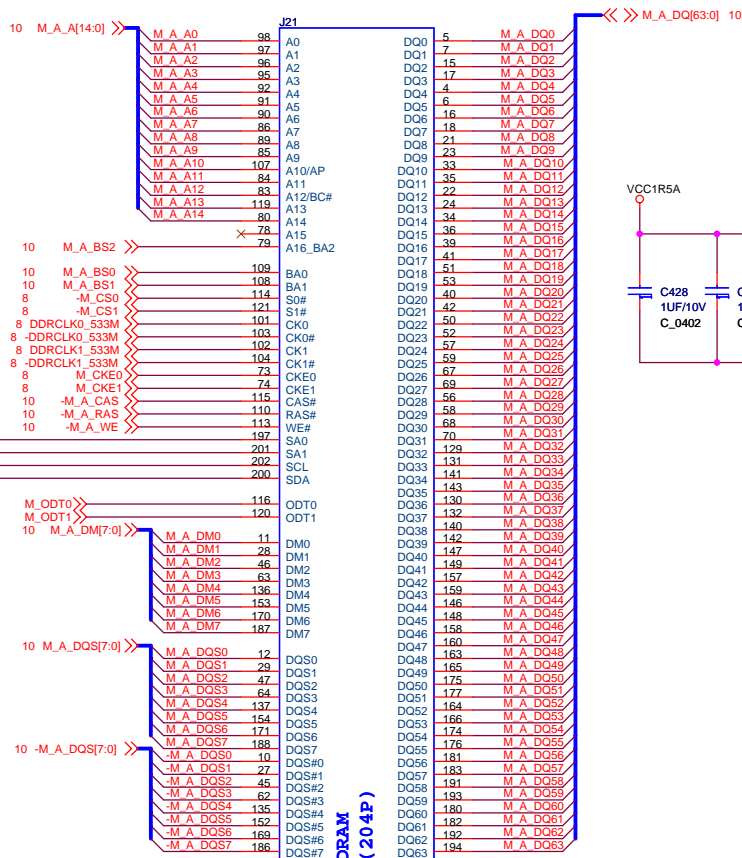
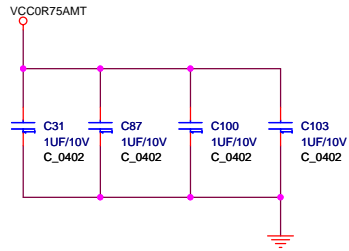
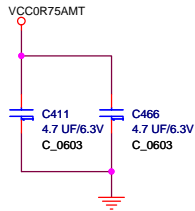
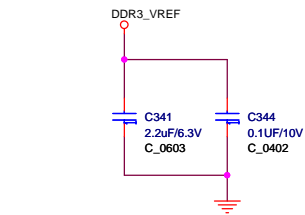

PLACE 1uF NEAR VCC1R5A PIN

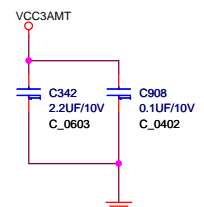
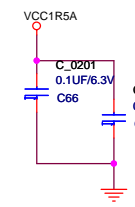

笔记本维修资料 <http://shop38669313.taobao.com>
 QQ:52643956

DESIGNER	<OrgAddr1>	
CHECKED	<OrgAddr2>	
APPROVED	<OrgAddr3>	Part No. 42X7359
CLASS	<OrgAddr4>	EC No. L52888
THIS DOCUMENT IS THE PROPERTY OF LENOVO. ITS USE IS AUTHORIZED ONLY FOR RESPONDING TO A REQUEST FOR QUOTATION OR FOR THE PERFORMANCE OF WORK FOR LENOVO. ALL QUESTIONS MUST BE REFERRED TO THE LENOVO PURCHASING DEPARTMENT.		
		TITLE: Kodachiz Ver: PDV
		DDR3 SO DIMM CHANNEL-A
LENOVO CONFIDENTIAL		sheet 15 of 102 Tuesday, October 30, 2007

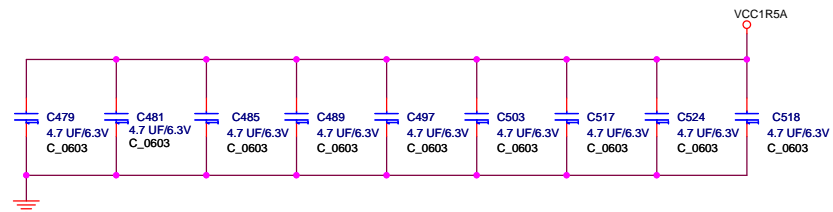
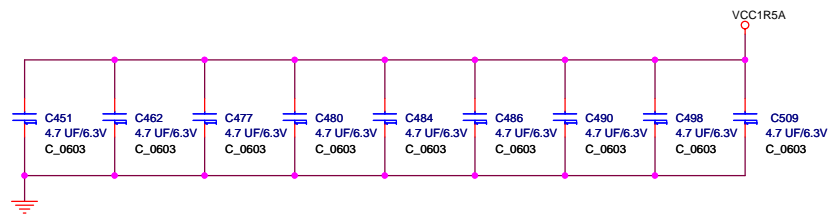
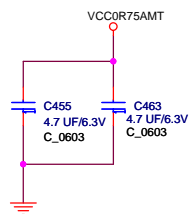

笔记本维修资料 <http://shop36609371.taobao.com>

QQ:52643956

DESIGNER	<OrgAddr1>	lenovo 联想
CHECKED	<OrgAddr2>	
APPROVED	<OrgAddr3>	Part No . 42X7359
CLASS	<OrgAddr4>	EC No . L52888
<small>THIS DOCUMENT IS THE PROPERTY OF LENOVO. ITS USE IS AUTHORIZED ONLY FOR RESPONDING TO A REQUEST FOR QUOTATION OR FOR THE PERFORMANCE OF WORK FOR LENOVO. ALL QUESTIONS MUST BE REFERRED TO THE LENOVO PURCHASING DEPARTMENT.</small>		TITLE: Kodachi2 Ver: PDV
		DDR3 DECOUPLING
LENOVO CONFIDENTIAL		sheet 17 of 102 Tuesday, October 30, 2007

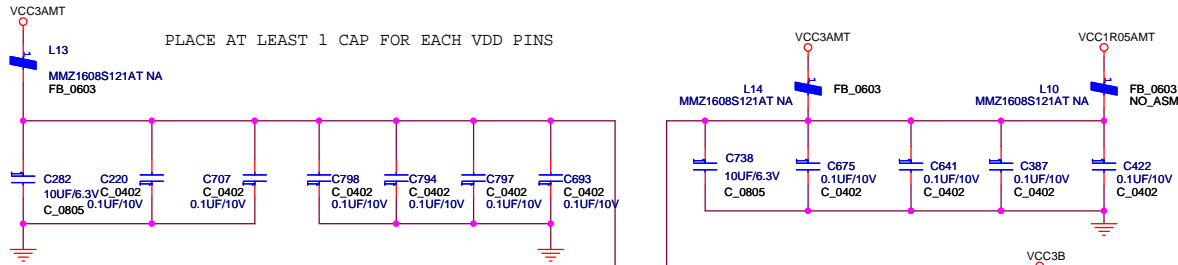

SRC#	OE#	DEVICE
0		
1		
2		INT GFX
3	OE#3	WLAN
4	OE#4	WWAN
5	OE#5	SATA
6	OE#6	WUSB
7		ICH
8	OE#8	MCH
9	OE#9	RESERVED
10		ITP

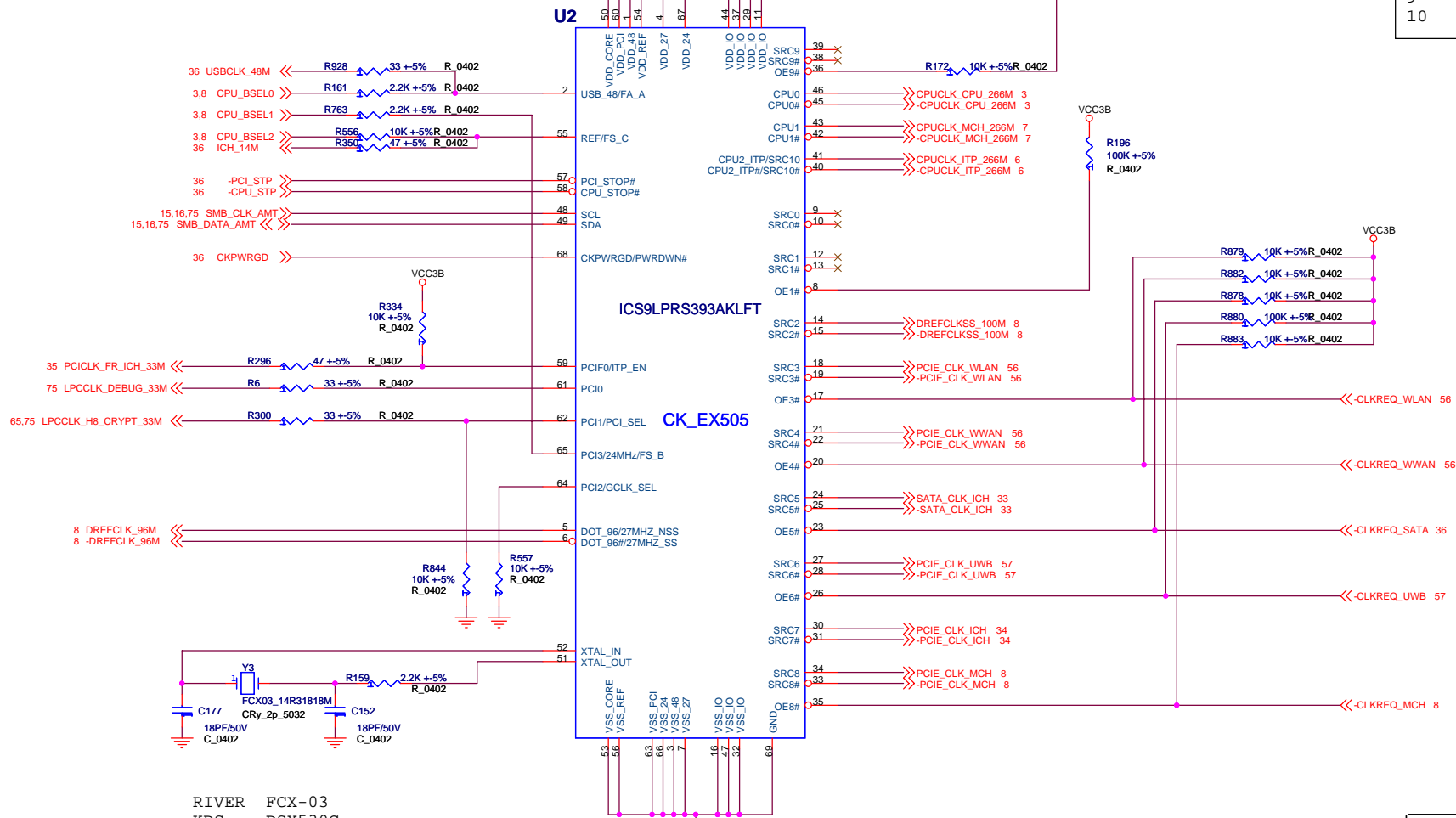

FSC	FSE	FSA	CPU
BSEL2	BSEL1	BSEL0	
0	1	1	166M
0	1	0	200M
0	0	0	266M
1	0	0	333M

RIVER FCX-03
KDS DSX530G

笔记本维修资料 <http://shop36609371.taobao.com>

QQ:52643956

DESIGNER	<OrgAddr1>	lenovo 联想
CHECKED	<OrgAddr2>	
APPROVED	<OrgAddr3>	Part No. 42X7359
CLASS	<OrgAddr4>	EC No. L52888
THIS DOCUMENT IS THE PROPERTY OF LENOVO. ITS USE IS AUTHORIZED ONLY FOR RESPONDING TO A REQUEST FOR QUOTATION OR FOR THE PERFORMANCE OF WORK FOR LENOVO. ALL QUESTIONS MUST BE REFERRED TO THE LENOVO PURCHASING DEPARTMENT.		TITLE: Kodachi2 Ver: PDV
		CLOCK GEN
LENOVO CONFIDENTIAL		sheet 18 of 102 Tuesday, October 30, 2007

BLANK PAGE

笔记本维修资料 <http://shop36609371.taobao.com>

QQ:52643956

DESIGNER	<OrgAddr1>	
CHECKED	<OrgAddr2>	
APPROVED	<OrgAddr3>	Part No . 42X7359
CLASS	<OrgAddr4>	EC No . L52888
<small>THIS DOCUMENT IS THE PROPERTY OF LENOVO. ITS USE IS AUTHORIZED ONLY FOR RESPONDING TO A REQUEST FOR QUOTATION OR FOR THE PERFORMANCE OF WORK FOR LENOVO. ALL QUESTIONS MUST BE REFERRED TO THE LENOVO PURCHASING DEPARTMENT.</small>		TITLE: Kodachi2 Ver: PDV
LENOVO CONFIDENTIAL		sheet 19 of 102 Tuesday, October 30, 2007

BLANK PAGE

笔记本维修资料 <http://shop36609371.taobao.com>

QQ:52643956

DESIGNER	<OrgAddr1>	
CHECKED	<OrgAddr2>	
APPROVED	<OrgAddr3>	Part No . 42X7359
CLASS	<OrgAddr4>	EC No . L52888
<small>THIS DOCUMENT IS THE PROPERTY OF LENOVO. ITS USE IS AUTHORIZED ONLY FOR RESPONDING TO A REQUEST FOR QUOTATION OR FOR THE PERFORMANCE OF WORK FOR LENOVO. ALL QUESTIONS MUST BE REFERRED TO THE LENOVO PURCHASING DEPARTMENT.</small>		TITLE: Kodachi2 Ver: PDV
LENOVO CONFIDENTIAL		sheet 20 of 102 Tuesday, October 30, 2007

BLANK PAGE

笔记本维修资料 <http://shop36609371.taobao.com>

QQ:52643956

DESIGNER	<OrgAddr1>	
CHECKED	<OrgAddr2>	
APPROVED	<OrgAddr3>	Part No . 42X7359
CLASS	<OrgAddr4>	EC No . L52888
<small>THIS DOCUMENT IS THE PROPERTY OF LENOVO. ITS USE IS AUTHORIZED ONLY FOR RESPONDING TO A REQUEST FOR QUOTATION OR FOR THE PERFORMANCE OF WORK FOR LENOVO. ALL QUESTIONS MUST BE REFERRED TO THE LENOVO PURCHASING DEPARTMENT.</small>		TITLE: Kodachi2 Ver: PDV
LENOVO CONFIDENTIAL		sheet 21 of 102 Tuesday, October 30, 2007

BLANK PAGE

笔记本维修资料 <http://shop36609371.taobao.com>

QQ:52643956

DESIGNER	<OrgAddr1>		
CHECKED	<OrgAddr2>		
APPROVED	<OrgAddr3>		Part No . 42X7359
CLASS	<OrgAddr4>		EC No . L52888
<small>THIS DOCUMENT IS THE PROPERTY OF LENOVO. ITS USE IS AUTHORIZED ONLY FOR RESPONDING TO A REQUEST FOR QUOTATION OR FOR THE PERFORMANCE OF WORK FOR LENOVO. ALL QUESTIONS MUST BE REFERRED TO THE LENOVO PURCHASING DEPARTMENT.</small>		TITLE: Kodachi2 Ver: PDV	
LENOVO CONFIDENTIAL		sheet 22 of 102 Tuesday, October 30, 2007	

BLANK PAGE

笔记本维修资料 <http://shop36609371.taobao.com>

QQ:52643956

DESIGNER	<OrgAddr1>	
CHECKED	<OrgAddr2>	
APPROVED	<OrgAddr3>	Part No . 42X7359
CLASS	<OrgAddr4>	EC No . L52888
<small>THIS DOCUMENT IS THE PROPERTY OF LENOVO. ITS USE IS AUTHORIZED ONLY FOR RESPONDING TO A REQUEST FOR QUOTATION OR FOR THE PERFORMANCE OF WORK FOR LENOVO. ALL QUESTIONS MUST BE REFERRED TO THE LENOVO PURCHASING DEPARTMENT.</small>		TITLE: Kodachi2 Ver: PDV
LENOVO CONFIDENTIAL		sheet 23 of 102 Tuesday, October 30, 2007

BLANK PAGE

笔记本维修资料 <http://shop36609371.taobao.com>

QQ:52643956

DESIGNER	<OrgAddr1>	
CHECKED	<OrgAddr2>	
APPROVED	<OrgAddr3>	Part No . 42X7359
CLASS	<OrgAddr4>	EC No . L52888
<small>THIS DOCUMENT IS THE PROPERTY OF LENOVO. ITS USE IS AUTHORIZED ONLY FOR RESPONDING TO A REQUEST FOR QUOTATION OR FOR THE PERFORMANCE OF WORK FOR LENOVO. ALL QUESTIONS MUST BE REFERRED TO THE LENOVO PURCHASING DEPARTMENT.</small>		TITLE: Kodachi2 Ver: PDV
LENOVO CONFIDENTIAL		sheet 24 of 102 Tuesday, October 30, 2007

BLANK PAGE

笔记本维修资料 <http://shop36609371.taobao.com>

QQ:52643956

DESIGNER	<OrgAddr1>	
CHECKED	<OrgAddr2>	
APPROVED	<OrgAddr3>	Part No . 42X7359
CLASS	<OrgAddr4>	EC No . L52888
<small>THIS DOCUMENT IS THE PROPERTY OF LENOVO. ITS USE IS AUTHORIZED ONLY FOR RESPONDING TO A REQUEST FOR QUOTATION OR FOR THE PERFORMANCE OF WORK FOR LENOVO. ALL QUESTIONS MUST BE REFERRED TO THE LENOVO PURCHASING DEPARTMENT.</small>		TITLE: Kodachi2 Ver: PDV
LENOVO CONFIDENTIAL		sheet 25 of 102 Tuesday, October 30, 2007

BLANK PAGE

笔记本维修资料 <http://shop36609371.taobao.com>

QQ:52643956

DESIGNER	<OrgAddr1>	
CHECKED	<OrgAddr2>	
APPROVED	<OrgAddr3>	Part No . 42X7359
CLASS	<OrgAddr4>	EC No . L52888
<small>THIS DOCUMENT IS THE PROPERTY OF LENOVO. ITS USE IS AUTHORIZED ONLY FOR RESPONDING TO A REQUEST FOR QUOTATION OR FOR THE PERFORMANCE OF WORK FOR LENOVO. ALL QUESTIONS MUST BE REFERRED TO THE LENOVO PURCHASING DEPARTMENT.</small>		TITLE: Kodachi2 Ver: PDV
LENOVO CONFIDENTIAL		sheet 26 of 102 Tuesday, October 30, 2007

BLANK PAGE

笔记本维修资料 <http://shop36609371.taobao.com>

QQ:52643956

DESIGNER	<OrgAddr1>	
CHECKED	<OrgAddr2>	
APPROVED	<OrgAddr3>	Part No . 42X7359
CLASS	<OrgAddr4>	EC No . L52888
<small>THIS DOCUMENT IS THE PROPERTY OF LENOVO. ITS USE IS AUTHORIZED ONLY FOR RESPONDING TO A REQUEST FOR QUOTATION OR FOR THE PERFORMANCE OF WORK FOR LENOVO. ALL QUESTIONS MUST BE REFERRED TO THE LENOVO PURCHASING DEPARTMENT.</small>		TITLE: Kodachi2 Ver: PDV
LENOVO CONFIDENTIAL		sheet 27 of 102 Tuesday, October 30, 2007

BLANK PAGE

笔记本维修资料 <http://shop36609371.taobao.com>

QQ:52643956

DESIGNER	<OrgAddr1>		
CHECKED	<OrgAddr2>		
APPROVED	<OrgAddr3>		Part No . 42X7359
CLASS	<OrgAddr4>		EC No . L52888
<small>THIS DOCUMENT IS THE PROPERTY OF LENOVO. ITS USE IS AUTHORIZED ONLY FOR RESPONDING TO A REQUEST FOR QUOTATION OR FOR THE PERFORMANCE OF WORK FOR LENOVO. ALL QUESTIONS MUST BE REFERRED TO THE LENOVO PURCHASING DEPARTMENT.</small>		TITLE: Kodachi2 Ver: PDV	
LENOVO CONFIDENTIAL		sheet 28 of 102 Tuesday, October 30, 2007	

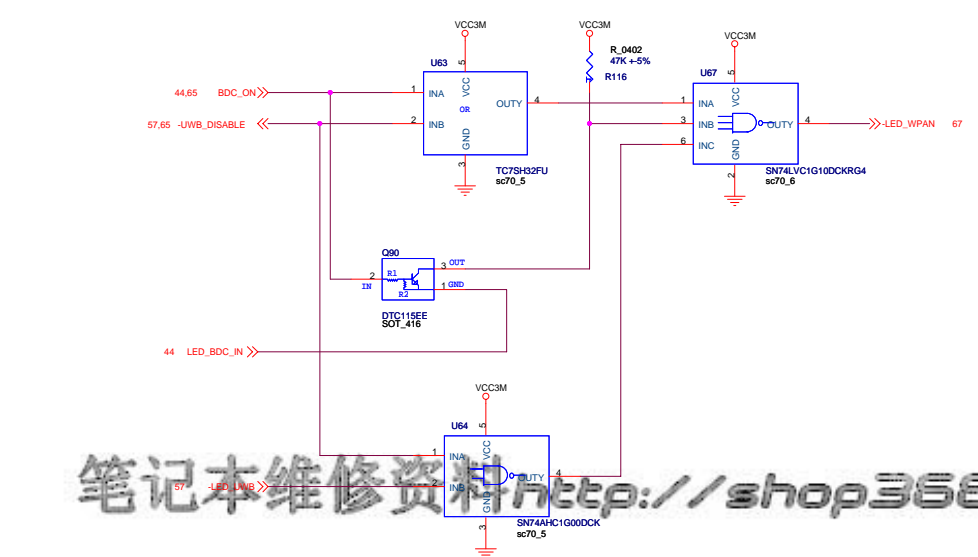
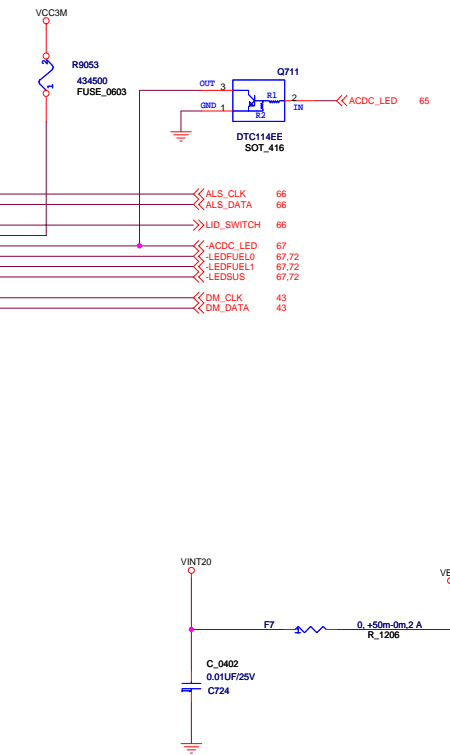
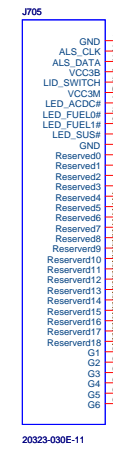
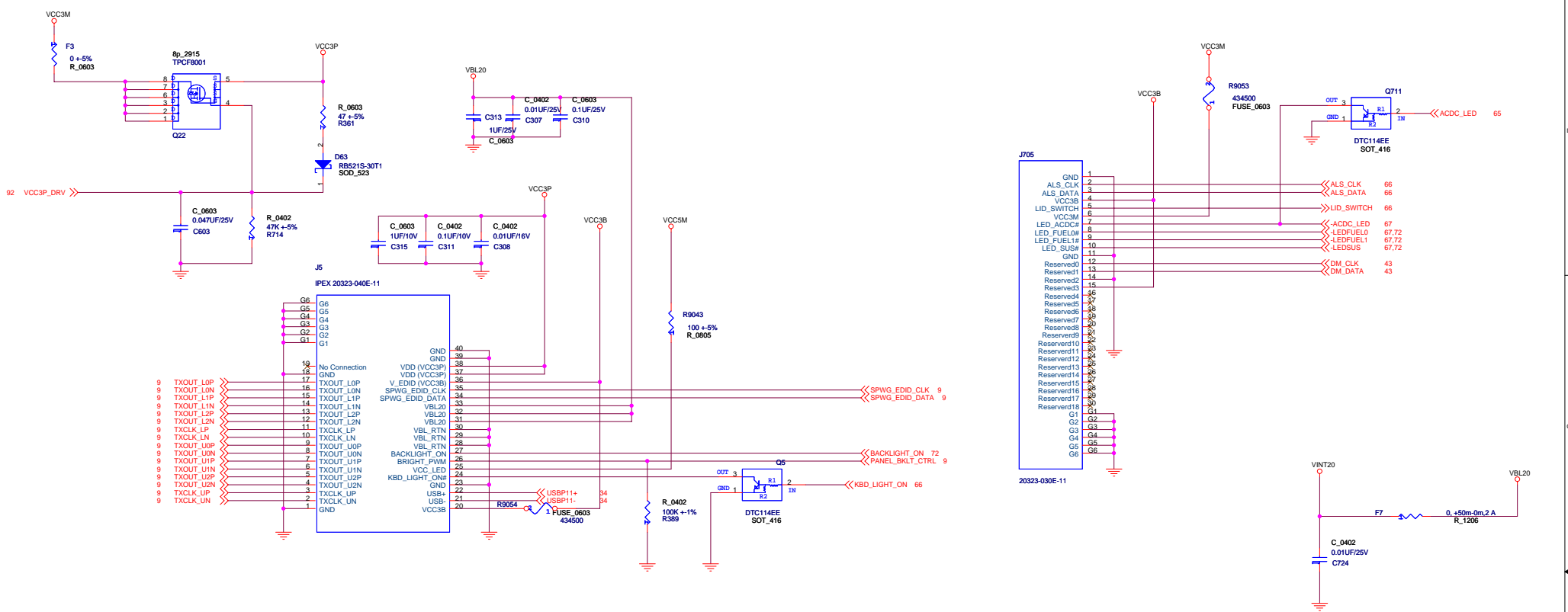

TABLE

	NON UWB MODEL	UWB MODEL
R1088	ASM	NO_ASM
U57	NO_ASM	ASM
U59	NO_ASM	ASM
U60	NO_ASM	ASM
U63	NO_ASM	ASM
U64	NO_ASM	ASM
Q90	NO_ASM	ASM
R1085	NO_ASM	ASM
R1086	NO_ASM	ASM
R1087	NO_ASM	ASM

笔记本维修资料 <http://shop36609371.taobao.com>

QQ:52643956

DESIGNER	<OrgAddr1>	
CHECKED	<OrgAddr2>	
APPROVED	<OrgAddr3>	
CLASS	<OrgAddr4>	Part No. 42X7359
<small>THIS DOCUMENT IS THE PROPERTY OF LENOVO. ITS USE IS AUTHORIZED ONLY FOR REPAIRING TO A REQUEST FOR QUOTATION OR FOR THE PERFORMANCE OF WORK FOR LENOVO. ALL QUESTIONS MUST BE REFERRED TO THE LENOVO PURCHASING DEPARTMENT.</small>		EC No. L52888
LCD CONNECTOR		TITLE: Kodach2 Ver: PDV
sheet 29 of 102		LCD CONNECTOR
LENOVO CONFIDENTIAL		sheet 29 of 102 Tuesday, October 30, 2007

笔记本维修资料 <http://shop36609371.taobao.com>

QQ:52643956

DESIGNER	<OrgAddr1>		
CHECKED	<OrgAddr2>		
APPROVED	<OrgAddr3>		Part No . 42X7359
CLASS	<OrgAddr4>		EC No . L52888
<small>THIS DOCUMENT IS THE PROPERTY OF LENOVO. ITS USE IS AUTHORIZED ONLY FOR RESPONDING TO A REQUEST FOR QUOTATION OR FOR THE PERFORMANCE OF WORK FOR LENOVO. ALL QUESTIONS MUST BE REFERRED TO THE LENOVO PURCHASING DEPARTMENT.</small>		TITLE: Kodachi2 Ver: PDV	
LENOVO CONFIDENTIAL		sheet 30 of 102 Tuesday, October 30, 2007	

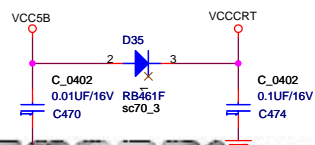
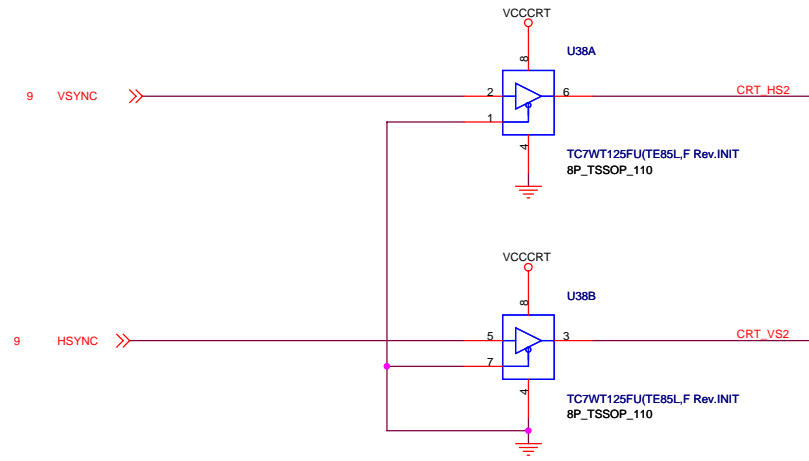
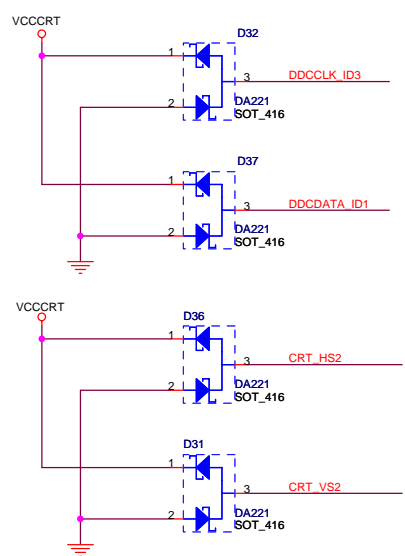
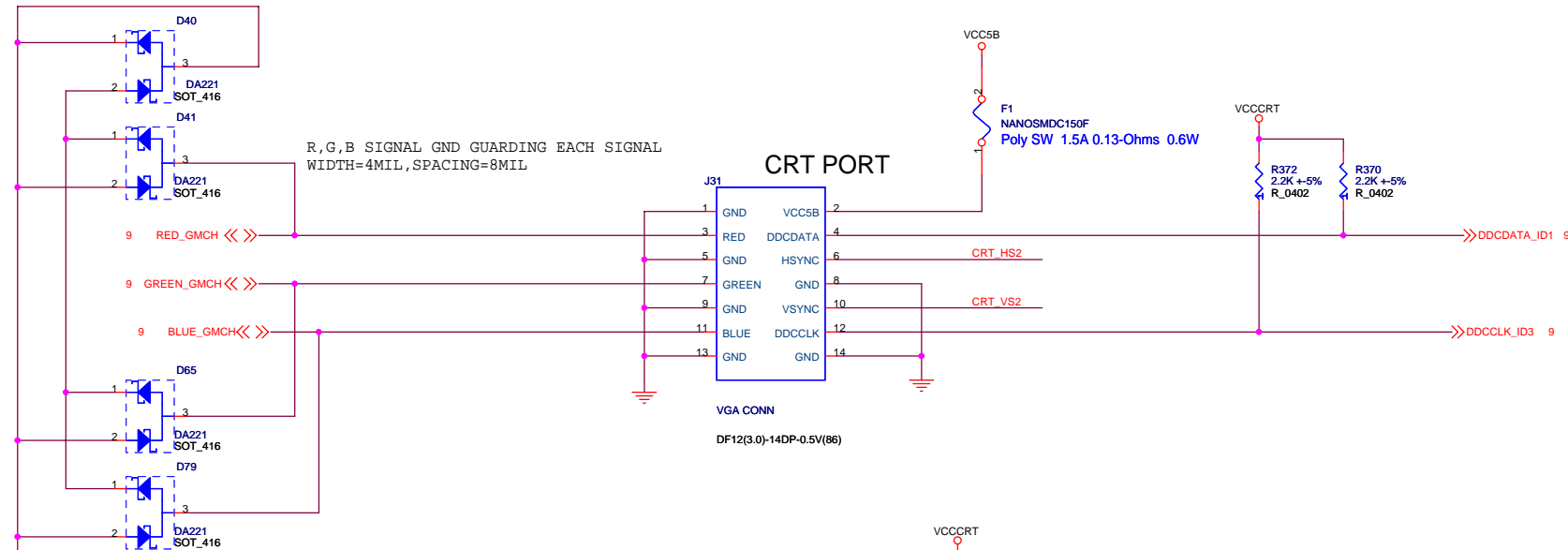

笔记本维修资料 <http://shop36609371.taobao.com>
QQ:52643956

DESIGNER	<OrgAddr1>	lenovo 联想
CHECKED	<OrgAddr2>	
APPROVED	<OrgAddr3>	Part No. 42X7359
CLASS	<OrgAddr4>	EC No. L52888
THIS DOCUMENT IS THE PROPERTY OF LENOVO. ITS USE IS AUTHORIZED ONLY FOR RESPONDING TO A REQUEST FOR QUOTATION OR FOR THE PERFORMANCE OF WORK FOR LENOVO. ALL QUESTIONS MUST BE REFERRED TO THE LENOVO PURCHASING DEPARTMENT.		
TITLE: Kodachi2 Ver: PDV		EXT CRT INTERFACE
LENOVO CONFIDENTIAL		sheet 31 of 102 Tuesday, October 30, 2007

笔记本维修资料 <http://shop36609371.taobao.com>
 QQ:52643956

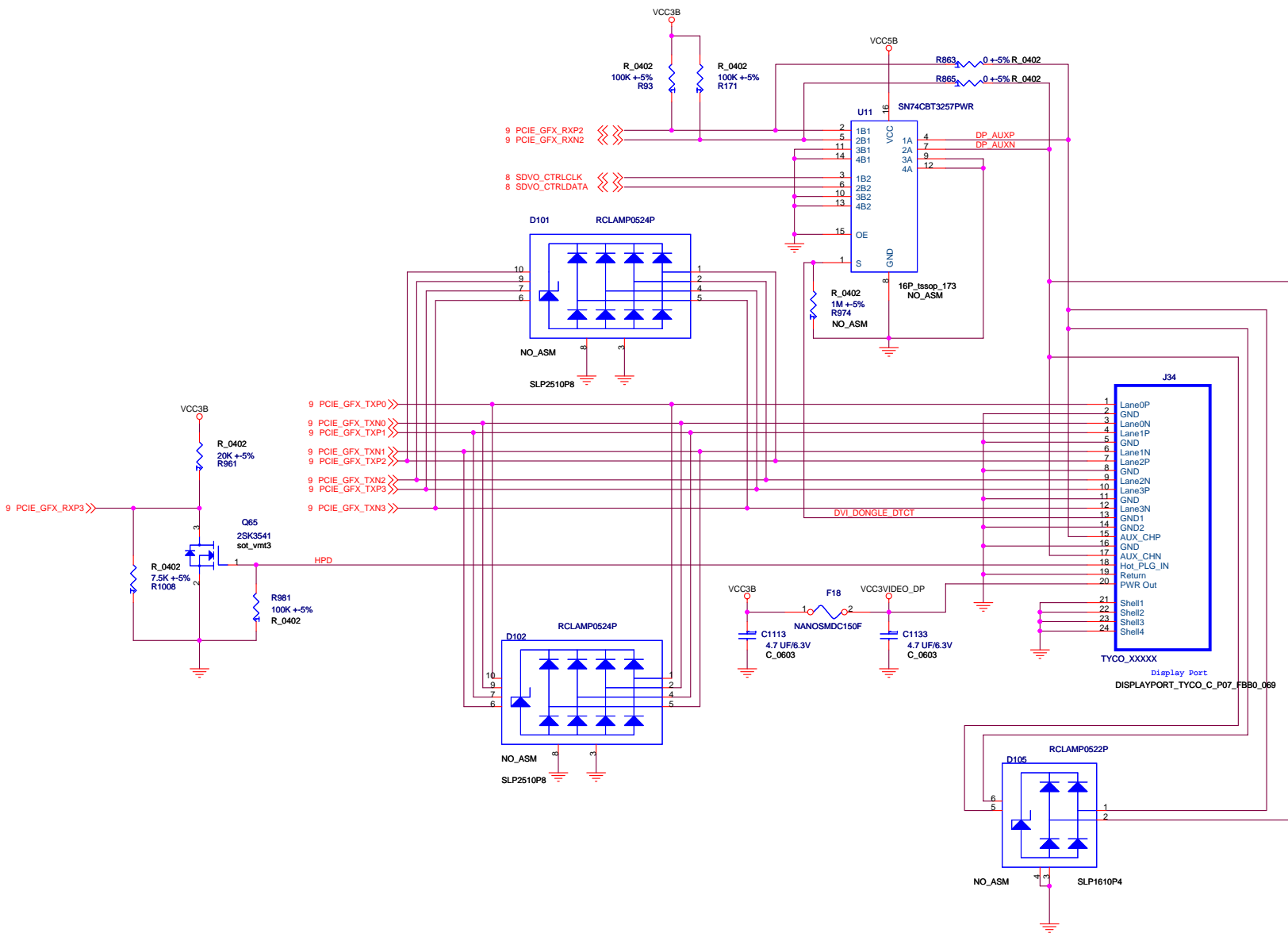

DESIGNER	<OrgAddr1>	
CHECKED	<OrgAddr2>	
APPROVED	<OrgAddr3>	Part No. 42X7359
CLASS	<OrgAddr4>	EC No. L52888
<small>THIS DOCUMENT IS THE PROPERTY OF LENOVO. ITS USE IS AUTHORIZED ONLY FOR RESPONDING TO A REQUEST FOR QUOTATION OR FOR THE PERFORMANCE OF WORK FOR LENOVO. ALL QUESTIONS MUST BE REFERRED TO THE LENOVO PURCHASING DEPARTMENT.</small>		TITLE: Kodachi2 Ver: PDV
LENOVO CONFIDENTIAL		DISPLAY PORT CONNECTOR
		sheet 32 of 102 Tuesday, October 30, 2007

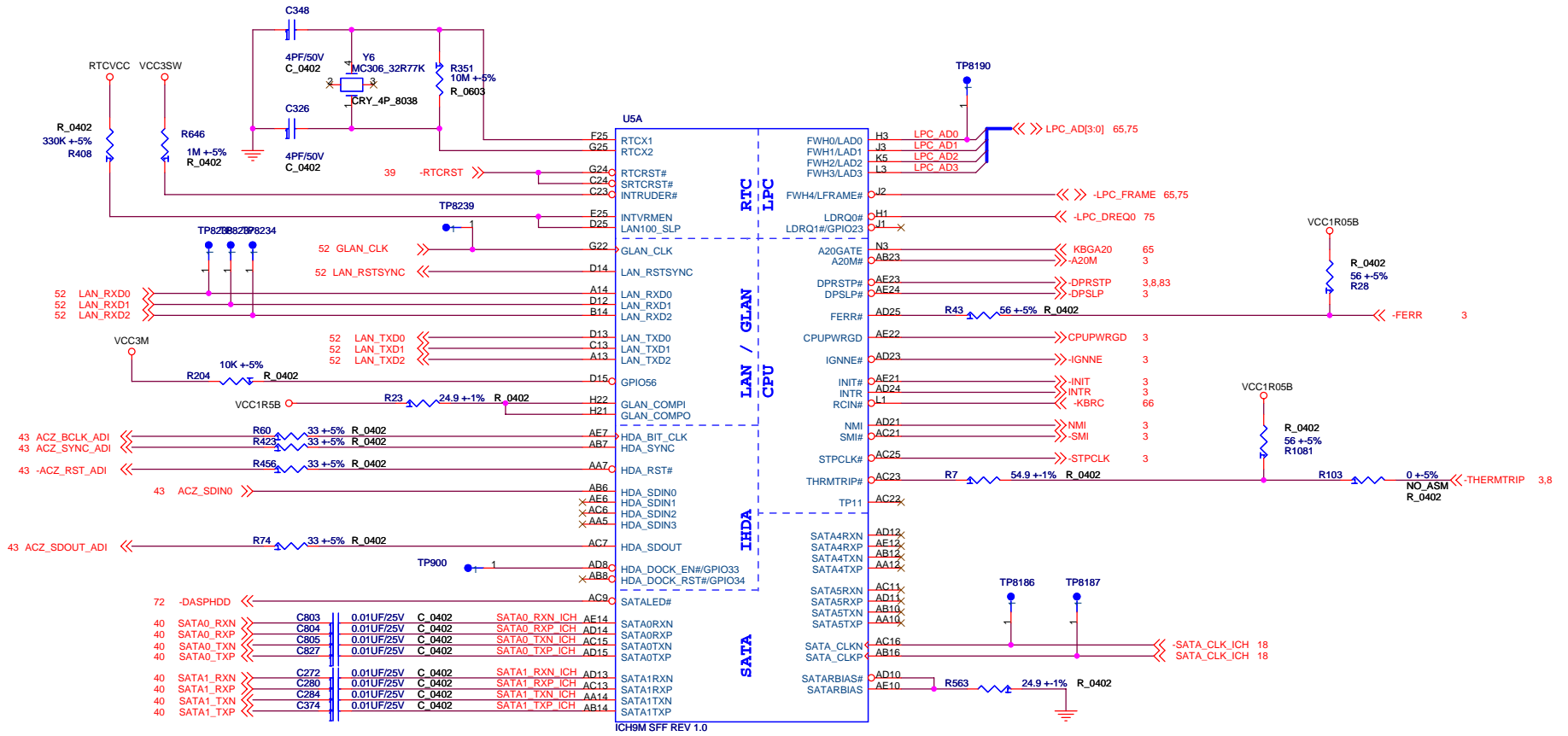

笔记本维修资料 <http://shop36609371.taobao.com>
 QQ:52643956

DESIGNER	<OrgAdd1>	
CHECKED	<OrgAdd2>	
APPROVED	<OrgAdd3>	Part No. 42X7359
CLASS	<OrgAdd4>	EC No. L52888
THIS DOCUMENT IS THE PROPERTY OF LENOVO. ITS USE IS AUTHORIZED ONLY FOR RESPONDING TO A REQUEST FOR QUOTATION OR FOR THE PERFORMANCE OF WORK FOR LENOVO. ALL QUESTIONS MUST BE REFERRED TO THE LENOVO PURCHASING DEPARTMENT.		
		TITLE: Kodach2 Ver: PDV
		ICH9-M(1/6) : SATA/HDA/GLAN/LPC
LENOVO CONFIDENTIAL		sheet 33 of 102 Tuesday, October 30, 2007

笔记本维修资料 <http://shop36609371.taobao.com>
 QQ:52643956

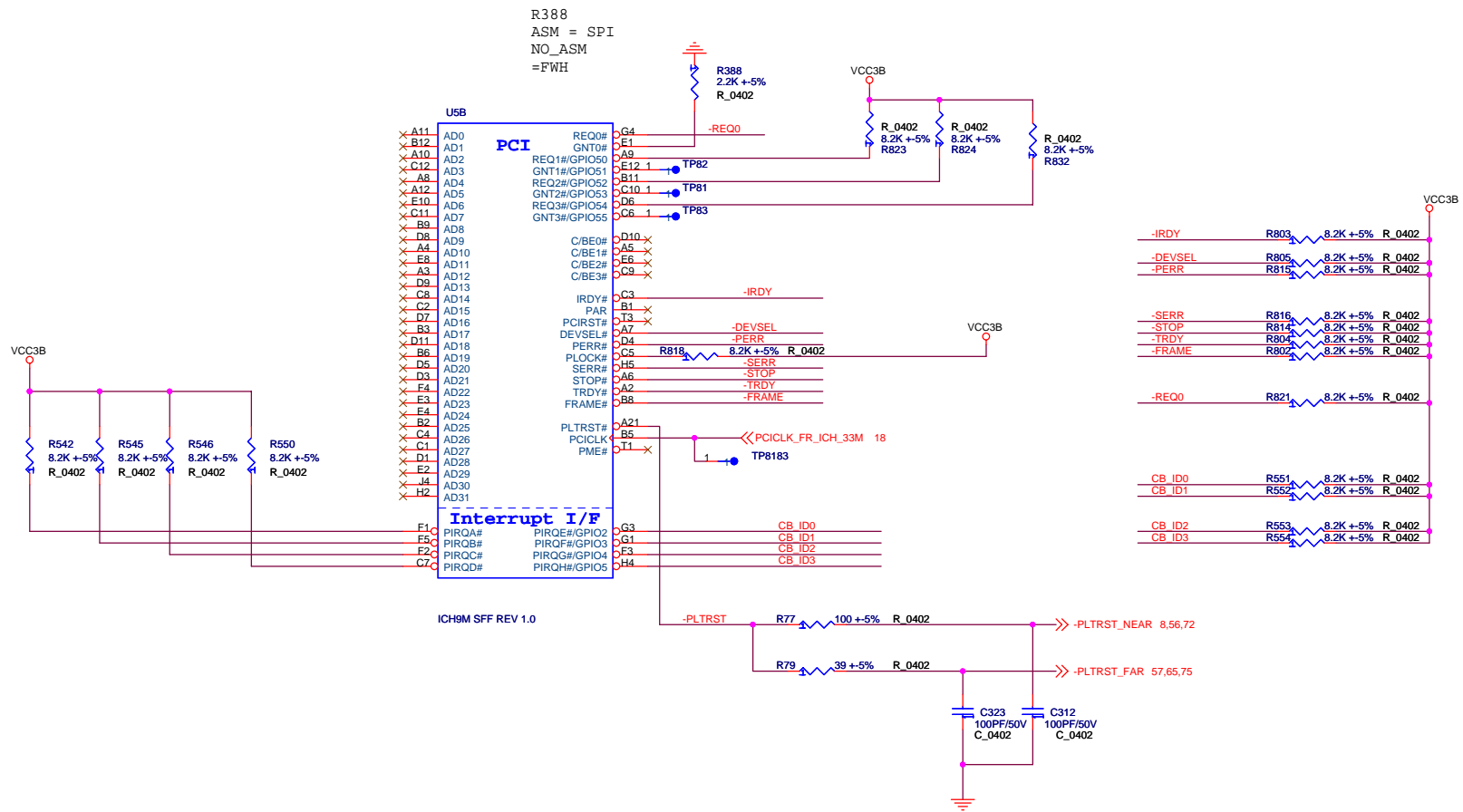

DESIGNER	<OrgAddr1>	lenovo 联想
CHECKED	<OrgAddr2>	
APPROVED	<OrgAddr3>	Part No. 42X7359
CLASS	<OrgAddr4>	EC No. L52888
THIS DOCUMENT IS THE PROPERTY OF LENOVO. ITS USE IS AUTHORIZED ONLY FOR RESPONDING TO A REQUEST FOR QUOTATION OR FOR THE PERFORMANCE OF WORK FOR LENOVO. ALL QUESTIONS MUST BE REFERRED TO THE LENOVO PURCHASING DEPARTMENT.		TITLE: Kodach2 Ver: PDV
		ICH9-M(3/6) : PCI/INTERRUPT
LENOVO CONFIDENTIAL		sheet 35 of 102 Tuesday, October 30, 2007

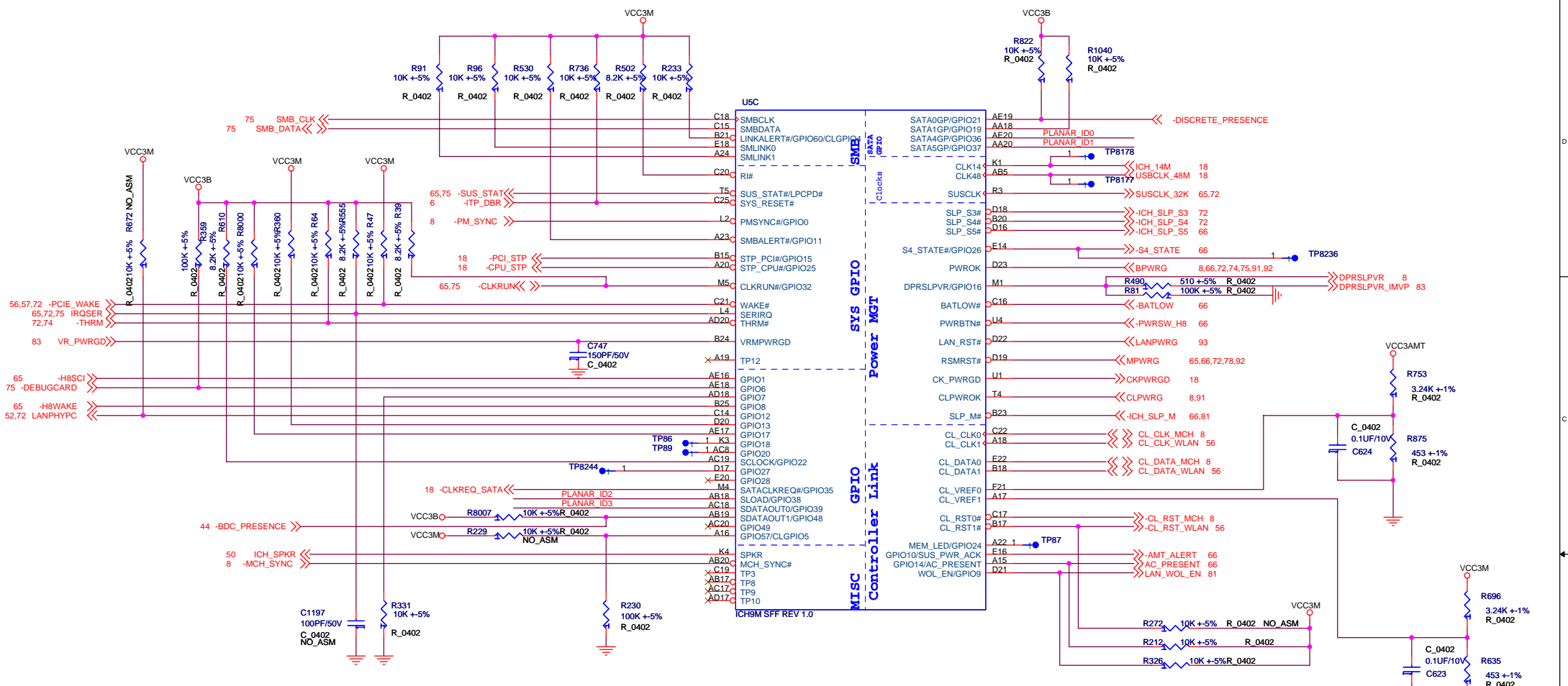

TABLE

PLANAR_ID	3	2	1	0
PULL-UP	R371	R505	R37	R671
PULL-DOWN	R346	R347	R113	R114

TABLE

LEVEL	PLANARID[3...0]
PREDV	0000B
SDV	0001B

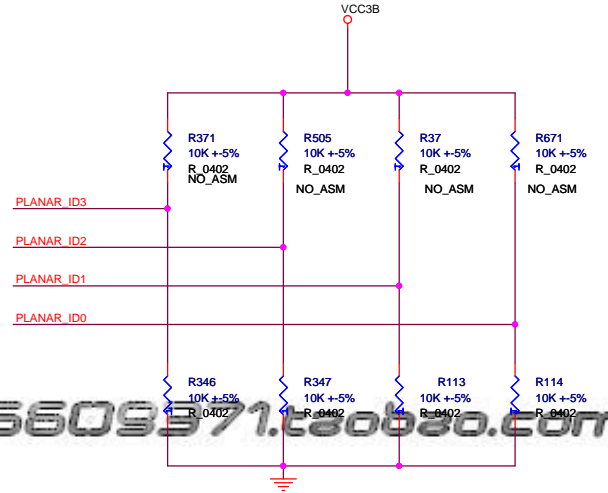

笔记本维修资料 <http://shop36609971.taobao.com>
 QQ:52643956

DESIGNER	<OrgAddr1>	
CHECKED	<OrgAddr2>	
APPROVED	<OrgAddr3>	Part No. 42X7359
CLASS	<OrgAddr4>	EC No. L52888
<small>THIS DOCUMENT IS THE PROPERTY OF LENOVO. ITS USE IS AUTHORIZED ONLY FOR RESPONDING TO A REQUEST FOR QUOTATION OR FOR THE PERFORMANCE OF WORK FOR LENOVO. ALL QUESTIONS MUST BE REFERRED TO THE LENOVO PURCHASING DEPARTMENT.</small>		
TITLE: KodaChi2 Ver: PDV		ICH9-M(4/6) : GPIO/CLK/PM
LENOVO CONFIDENTIAL		sheet 36 of 102 Tuesday, October 30, 2007

USE

B4	VSS[001]	VSS[107]	U5
B7	VSS[002]	VSS[108]	U10
B10	VSS[003]	VSS[109]	W11
B16	VSS[004]	VSS[110]	W14
B19	VSS[005]	VSS[111]	W16
B22	VSS[006]	VSS[112]	U21
D2	VSS[007]	VSS[113]	U22
D24	VSS[008]	VSS[114]	U25
E5	VSS[009]	VSS[115]	V3
E7	VSS[010]	VSS[116]	V8
E9	VSS[011]	VSS[117]	V19
E11	VSS[012]	VSS[118]	V23
E13	VSS[013]	VSS[119]	W1
E15	VSS[014]	VSS[120]	W4
E17	VSS[015]	VSS[121]	W5
E19	VSS[016]	VSS[122]	W7
E21	VSS[017]	VSS[123]	W9
F24	VSS[018]	VSS[124]	W15
G2	VSS[019]	VSS[125]	W19
G5	VSS[020]	VSS[126]	W21
G10	VSS[021]	VSS[127]	W22
G13	VSS[022]	VSS[128]	W25
G16	VSS[023]	VSS[129]	Y3
G19	VSS[024]	VSS[130]	Y23
G21	VSS[025]	VSS[131]	AA1
H10	VSS[026]	VSS[132]	AA4
H12	VSS[027]	VSS[133]	AA6
H18	VSS[028]	VSS[134]	AA8
H23	VSS[029]	VSS[135]	AA11
J5	VSS[030]	VSS[136]	AA13
J9	VSS[031]	VSS[137]	AA15
J10	VSS[032]	VSS[138]	AA16
J11	VSS[033]	VSS[139]	AA17
J12	VSS[034]	VSS[140]	AA19
J13	VSS[035]	VSS[141]	AA21
J15	VSS[036]	VSS[142]	AA22
J21	VSS[037]	VSS[143]	AA25
J22	VSS[038]	VSS[144]	AB3
J25	VSS[039]	VSS[145]	AB9
K2	VSS[040]	VSS[146]	AB11
K9	VSS[041]	VSS[147]	AB13
K10	VSS[042]	VSS[148]	AB15
K11	VSS[043]	VSS[149]	AC24
K12	VSS[044]	VSS[150]	AC1
K13	VSS[045]	VSS[151]	AC4
K15	VSS[046]	VSS[152]	AC10
K17	VSS[047]	VSS[153]	AC12
K23	VSS[048]	VSS[154]	AC14
L5	VSS[049]	VSS[155]	AD2
L9	VSS[050]	VSS[156]	AD6
L10	VSS[051]	VSS[157]	AD9
L16	VSS[052]	VSS[158]	AD16
L17	VSS[053]	VSS[159]	AD19
L21	VSS[054]	VSS[160]	AD22
L22	VSS[055]	VSS[161]	AE3
L25	VSS[056]	VSS[162]	AE4
M9	VSS[057]	VSS[163]	AE11
M10	VSS[058]	VSS[164]	AE13
M12	VSS[059]	VSS[165]	AE15
M13	VSS[060]	VSS[166]	V17
M14	VSS[061]	VSS[167]	AE8
M16	VSS[062]	VSS[168]	Y9
M17	VSS[063]	VSS[169]	J16
M23	VSS[064]		
N2	VSS[065]		
N5	VSS[066]		
N8	VSS[067]		
N10	VSS[068]		
N12	VSS[069]		
N13	VSS[070]		
N14	VSS[071]		
N16	VSS[072]		
N17	VSS[073]		
N21	VSS[074]		
N22	VSS[075]		
N25	VSS[076]		
P9	VSS[077]		
P10	VSS[078]		
P12	VSS[079]		
P13	VSS[080]		
P14	VSS[081]		
P16	VSS[082]		
P17	VSS[083]		
P23	VSS[084]		
R5	VSS[085]		
R7	VSS[086]		
R8	VSS[087]		
R9	VSS[088]		
R10	VSS[089]		
R16	VSS[090]		
R17	VSS[091]		
R19	VSS[092]		
R21	VSS[093]		
R22	VSS[094]		
R25	VSS[095]		
T2	VSS[096]		
T8	VSS[097]		
T10	VSS[098]		
T11	VSS[099]		
T12	VSS[100]		
T13	VSS[101]		
T14	VSS[102]		
T15	VSS[103]		
T16	VSS[104]		
T23	VSS[105]		
	VSS[106]		

Add four corner test point for solder check



笔记本维修资料 <http://shop36609371.taobao.com>
 QQ:52643956

ICH9M SFF REV 1.0

DESIGNER	<OrgAddr1>	lenovo 联想
CHECKED	<OrgAddr2>	
APPROVED	<OrgAddr3>	Part No . 42X7359
CLASS	<OrgAddr4>	EC No . L52888
<small>THIS DOCUMENT IS THE PROPERTY OF LENOVO. ITS USE IS AUTHORIZED ONLY FOR RESPONDING TO A REQUEST FOR QUOTATION OR FOR THE PERFORMANCE OF WORK FOR LENOVO. ALL QUESTIONS MUST BE REFERRED TO THE LENOVO PURCHASING DEPARTMENT.</small>		TITLE: Kodach2 Ver: PDV
		ICH9-M(6/6) : GND
LENOVO CONFIDENTIAL		sheet 38 of 102 Tuesday, October 30, 2007

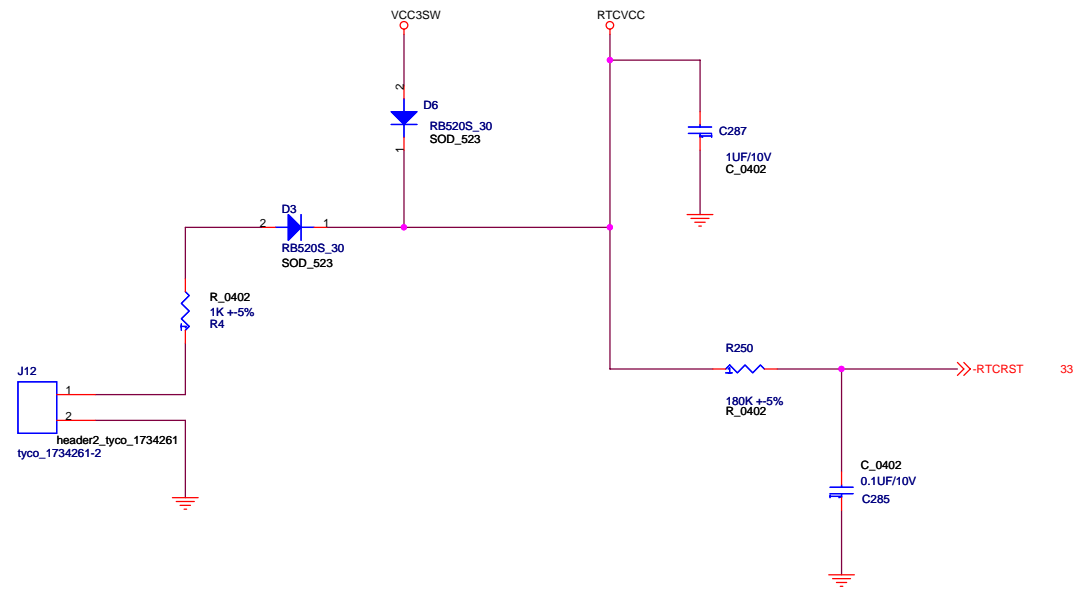

笔记本维修资料 <http://shop36609371.taobao.com>
 QQ:52643956

DESIGNER	<OrgAddr1>	lenovo 联想
CHECKED	<OrgAddr2>	
APPROVED	<OrgAddr3>	Part No. 42X7359
CLASS	<OrgAddr4>	EC No. L52888
<small>THIS DOCUMENT IS THE PROPERTY OF LENOVO. ITS USE IS AUTHORIZED ONLY FOR RESPONDING TO A REQUEST FOR QUOTATION OR FOR THE PERFORMANCE OF WORK FOR LENOVO. ALL QUESTIONS MUST BE REFERRED TO THE LENOVO PURCHASING DEPARTMENT.</small>		TITLE: Kodachi2 Ver: PDV
		RTC BATTERY
LENOVO CONFIDENTIAL		sheet 39 of 102 Tuesday, October 30, 2007

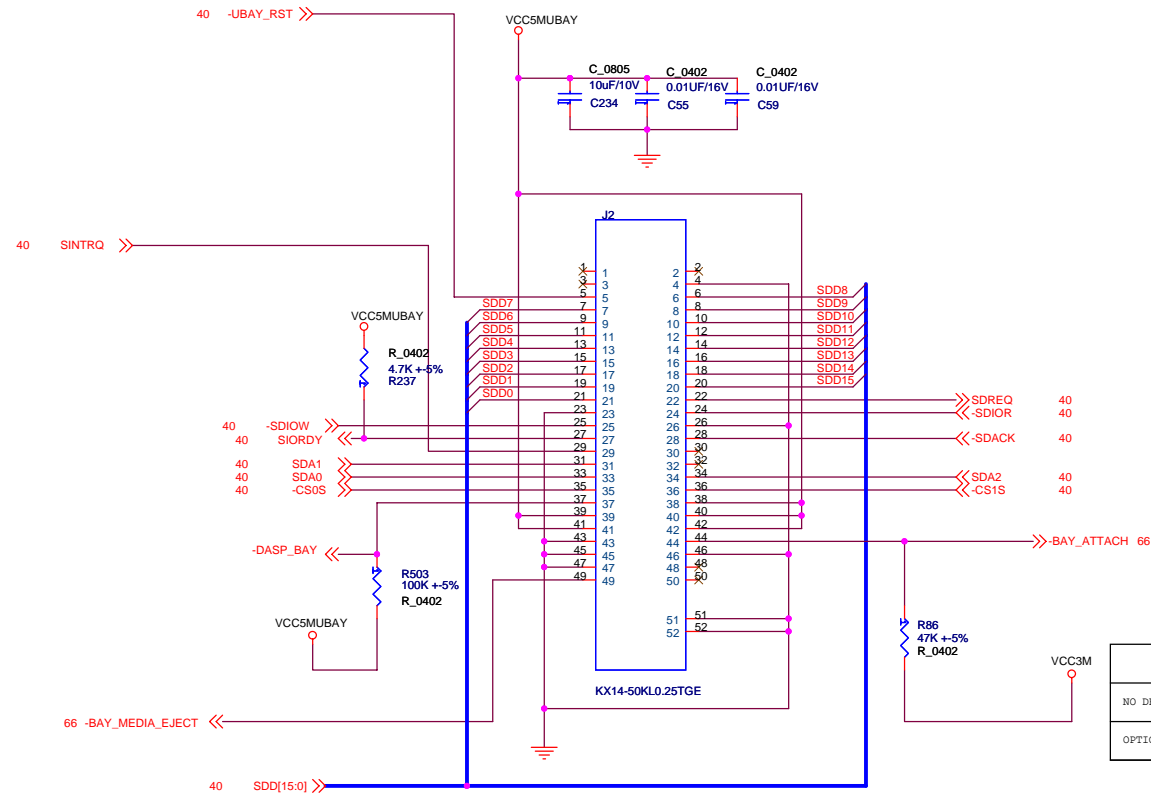

	-BAY_ATTACH
NO DEVICE	H
OPTICAL	L

笔记本维修资料 <http://shop36609371.taobao.com>
 QQ:52643956

DESIGNER	<OrgAddr1>	
CHECKED	<OrgAddr2>	
APPROVED	<OrgAddr3>	Part No. 42X7359
CLASS	<OrgAddr4>	EC No. L52888
<small>THIS DOCUMENT IS THE PROPERTY OF LENOVO. ITS USE IS AUTHORIZED ONLY FOR RESPONDING TO A REQUEST FOR QUOTATION OR FOR THE PERFORMANCE OF WORK FOR LENOVO. ALL QUESTIONS MUST BE REFERRED TO THE LENOVO PURCHASING DEPARTMENT.</small>		TITLE: Kodachi2 Ver: PDV
		SATA BAY I/F CONN
LENOVO CONFIDENTIAL		sheet 41 of 102 Tuesday, October 30, 2007

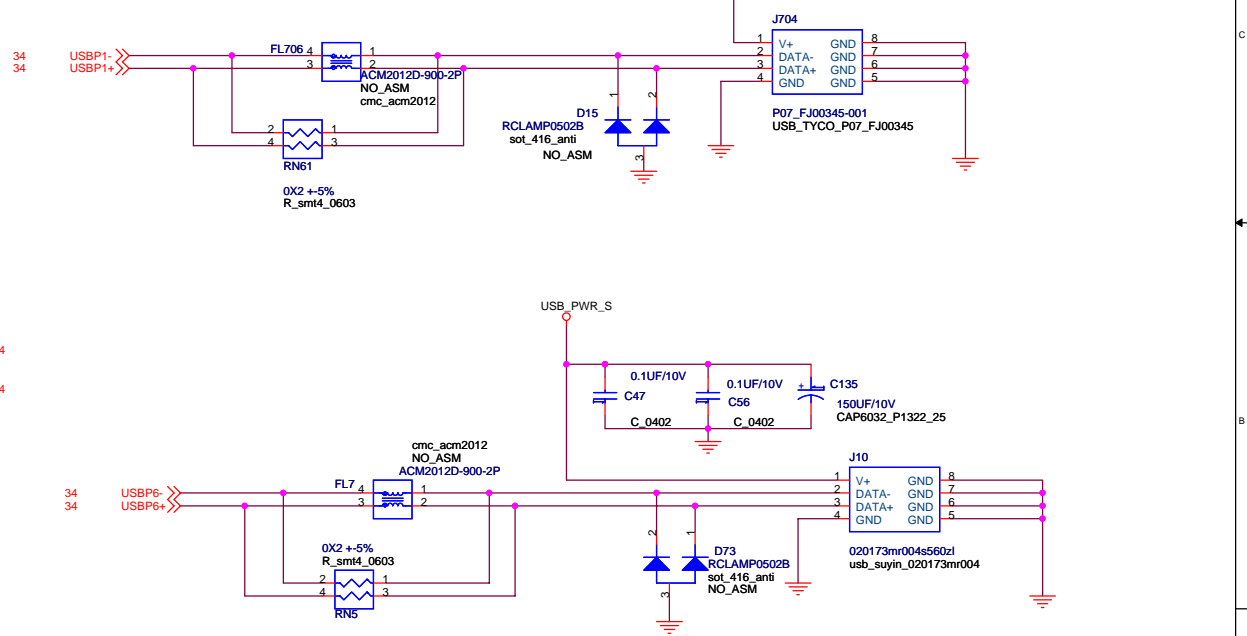
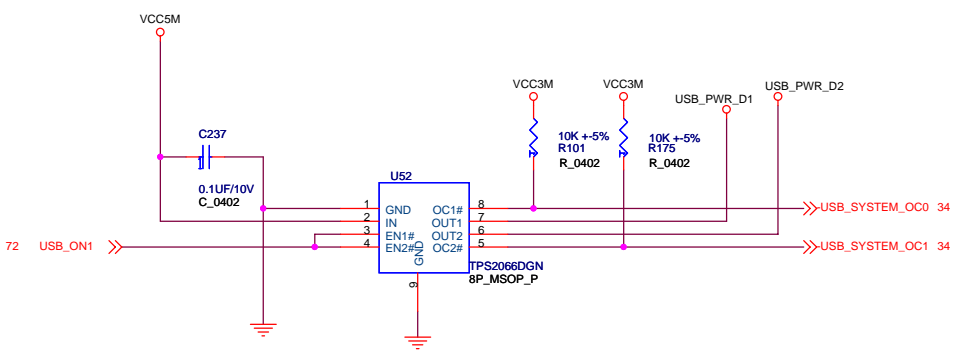
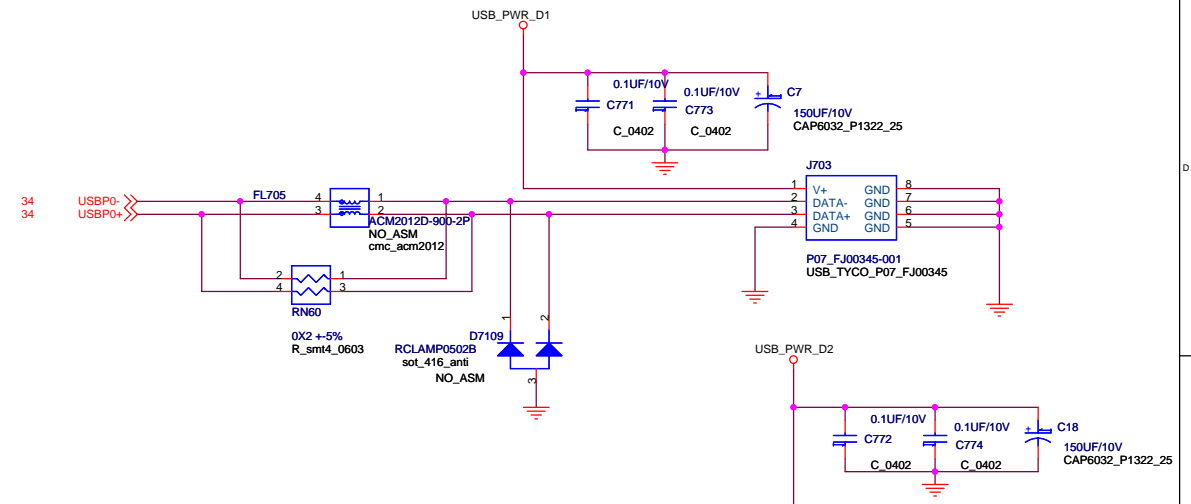
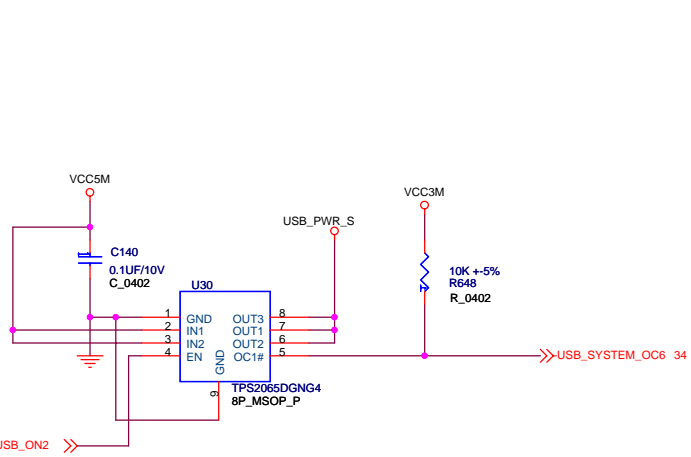

笔记本维修资料 <http://shop36609371.taobao.com>
 QQ:52643956

DESIGNER	<OrgAddr1>	lenovo 联想
CHECKED	<OrgAddr2>	
APPROVED	<OrgAddr3>	Part No. 42X7359
CLASS	<OrgAddr4>	EC No. L52888
THIS DOCUMENT IS THE PROPERTY OF LENOVO. ITS USE IS AUTHORIZED ONLY FOR RESPONDING TO A REQUEST FOR QUOTATION OR FOR THE PERFORMANCE OF WORK FOR LENOVO. ALL QUESTIONS MUST BE REFERRED TO THE LENOVO PURCHASING DEPARTMENT.		TITLE: Kodachi2 Ver: PDV
LENOVO CONFIDENTIAL		USB POWER/CONN
		sheet 42 of 102 Tuesday, October 30, 2007

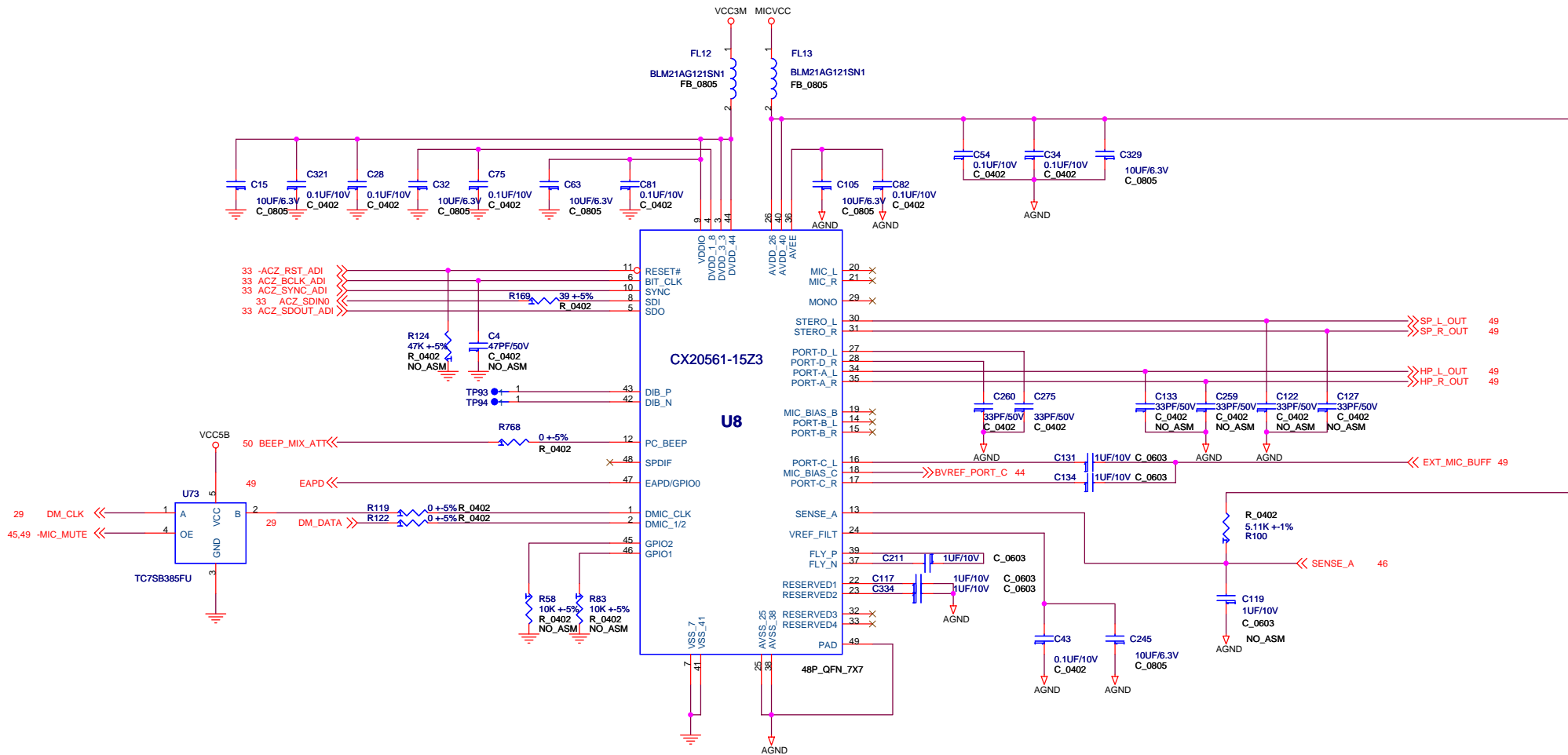

PLACE UNDER CX20561

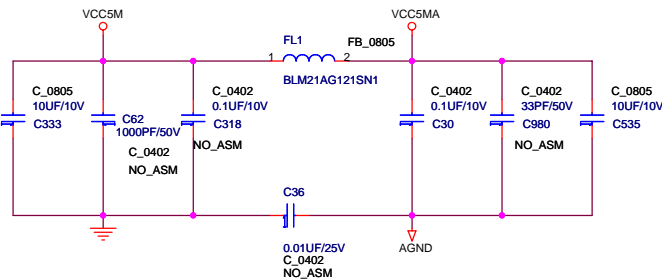
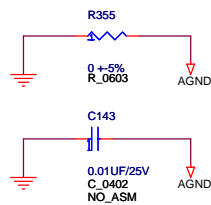

笔记本维修资料 <http://shop36609371.taobao.com>

QQ:52643956

DESIGNER	<OrgAddr1>	lenovo 联想
CHECKED	<OrgAddr2>	
APPROVED	<OrgAddr3>	Part No. 42X7359
CLASS	<OrgAddr4>	EC No. L52888
THIS DOCUMENT IS THE PROPERTY OF LENOVO. ITS USE IS AUTHORIZED ONLY FOR RESPONDING TO A REQUEST FOR QUOTATION OR FOR THE PERFORMANCE OF WORK FOR LENOVO. ALL QUESTIONS MUST BE REFERRED TO THE LENOVO PURCHASING DEPARTMENT.		TITLE: Kodachi2 Ver: PDV
		AUDIO CX20561
LENOVO CONFIDENTIAL		sheet 43 of 102 Tuesday, October 30, 2007

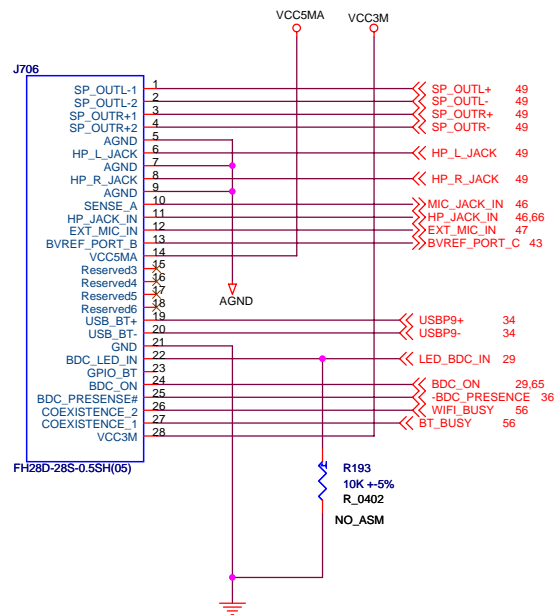

笔记本维修资料 <http://shop36609371.taobao.com>

QQ:52643956

DESIGNER	<OrgAddr1>	lenovo 联想
CHECKED	<OrgAddr2>	
APPROVED	<OrgAddr3>	
CLASS	<OrgAddr4>	
<small>THIS DOCUMENT IS THE PROPERTY OF LENOVO. ITS USE IS AUTHORIZED ONLY FOR RESPONDING TO A REQUEST FOR QUOTATION OR FOR THE PERFORMANCE OF WORK FOR LENOVO. ALL QUESTIONS MUST BE REFERRED TO THE LENOVO PURCHASING DEPARTMENT.</small>		Part No . 42X7359
		EC No . L52888
		TITLE: Kodachi2 Ver: PDV
		AUDIO MISC
LENOVO CONFIDENTIAL		sheet 44 of 102 Tuesday, October 30, 2007

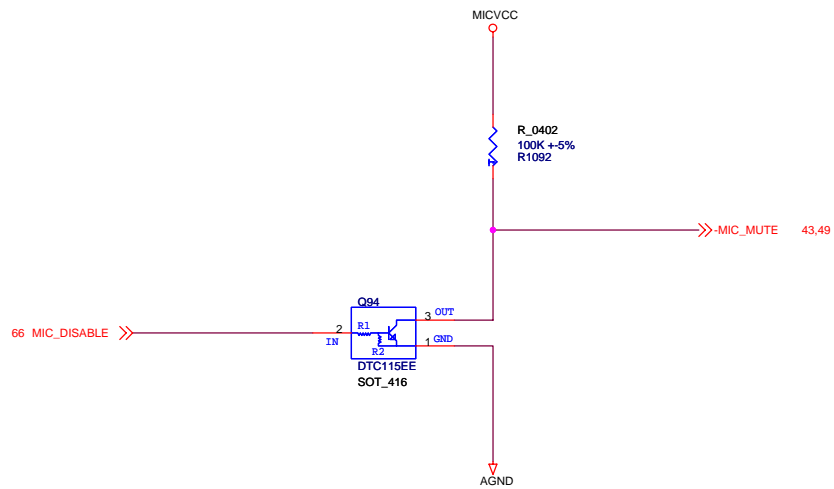
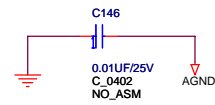
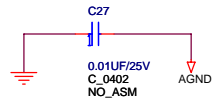

笔记本维修资料 <http://shop36609371.taobao.com>

QQ:52643956

DESIGNER	<OrgAddr1>	
CHECKED	<OrgAddr2>	
APPROVED	<OrgAddr3>	Part No . 42X7359
CLASS	<OrgAddr4>	EC No . L52888
THIS DOCUMENT IS THE PROPERTY OF LENOVO. ITS USE IS AUTHORIZED ONLY FOR RESPONDING TO A REQUEST FOR QUOTATION OR FOR THE PERFORMANCE OF WORK FOR LENOVO. ALL QUESTIONS MUST BE REFERRED TO THE LENOVO PURCHASING DEPARTMENT.		TITLE: Kodachi2 Ver: PDV
		BLANK
LENOVO CONFIDENTIAL		sheet 45 of 102 Tuesday, October 30, 2007

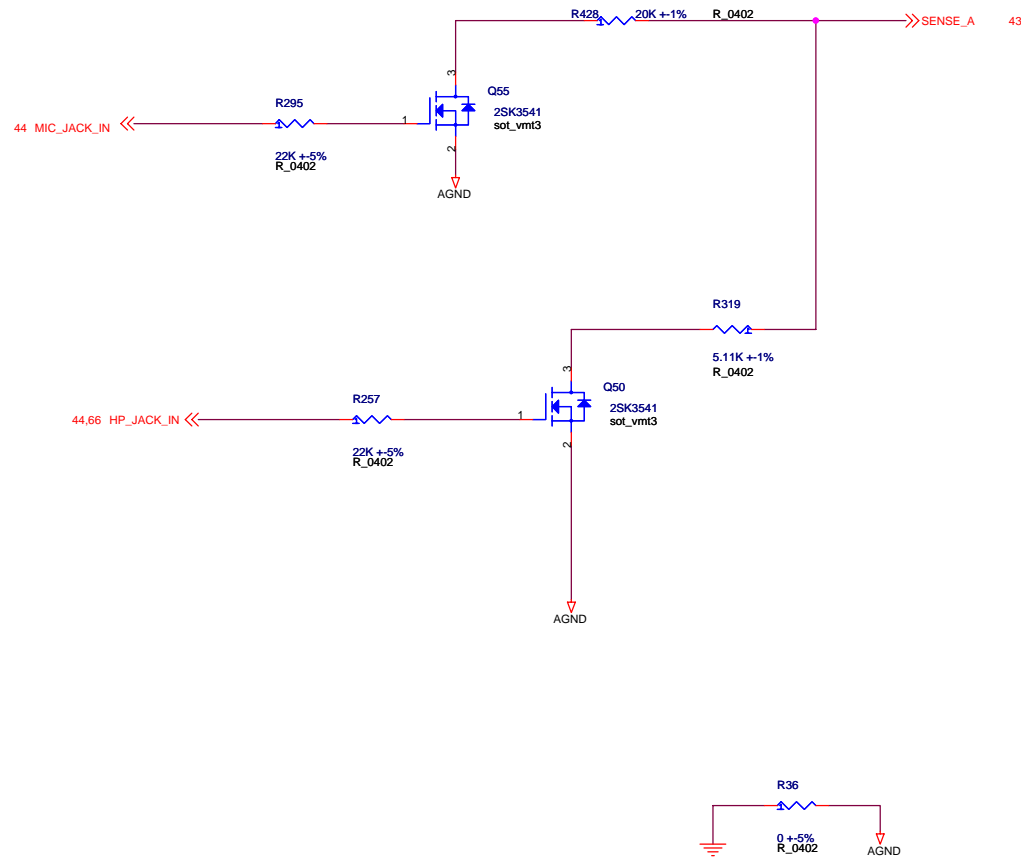

笔记本维修资料 <http://shop36609371.taobao.com>
 QQ:52643956

DESIGNER	<OrgAddr1>	lenovo 联想
CHECKED	<OrgAddr2>	
APPROVED	<OrgAddr3>	Part No . 42X7359
CLASS	<OrgAddr4>	EC No . L52888
<small>THIS DOCUMENT IS THE PROPERTY OF LENOVO. ITS USE IS AUTHORIZED ONLY FOR RESPONDING TO A REQUEST FOR QUOTATION OR FOR THE PERFORMANCE OF WORK FOR LENOVO. ALL QUESTIONS MUST BE REFERRED TO THE LENOVO PURCHASING DEPARTMENT.</small>		TITLE: Kodachi2 Ver: PDV
		EXT MIC JACK
LENOVO CONFIDENTIAL		sheet 46 of 102 Tuesday, October 30, 2007

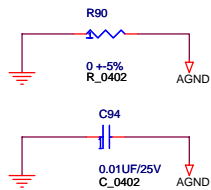
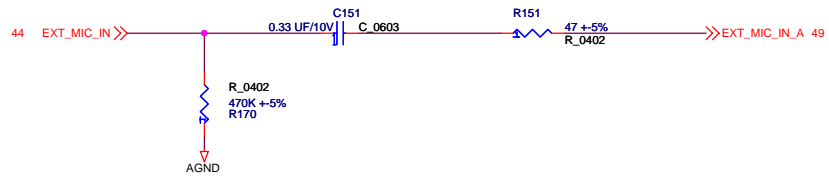

笔记本维修资料 <http://shop36609371.taobao.com>

QQ:52643956

DESIGNER	<OrgAddr1>	lenovo 联想
CHECKED	<OrgAddr2>	
APPROVED	<OrgAddr3>	
CLASS	<OrgAddr4>	
<small>THIS DOCUMENT IS THE PROPERTY OF LENOVO. ITS USE IS AUTHORIZED ONLY FOR RESPONDING TO A REQUEST FOR QUOTATION OR FOR THE PERFORMANCE OF WORK FOR LENOVO. ALL QUESTIONS MUST BE REFERRED TO THE LENOVO PURCHASING DEPARTMENT.</small>		Part No . 42X7359
		EC No . L52888
		TITLE: Kodachi2 Ver: PDV
		AUDIO EXT MIC AMP
LENOVO CONFIDENTIAL		sheet 47 of 102 Tuesday, October 30, 2007

笔记本维修资料 <http://shop36609371.taobao.com>

QQ:52643956

DESIGNER	<OrgAddr1>	
CHECKED	<OrgAddr2>	
APPROVED	<OrgAddr3>	Part No . 42X7359
CLASS	<OrgAddr4>	EC No . L52888
<small>THIS DOCUMENT IS THE PROPERTY OF LENOVO. ITS USE IS AUTHORIZED ONLY FOR RESPONDING TO A REQUEST FOR QUOTATION OR FOR THE PERFORMANCE OF WORK FOR LENOVO. ALL QUESTIONS MUST BE REFERRED TO THE LENOVO PURCHASING DEPARTMENT.</small>		TITLE: Kodachi2 Ver: PDV
		BLOCK DIAGRAM
LENOVO CONFIDENTIAL		sheet 48 of 102 Tuesday, October 30, 2007

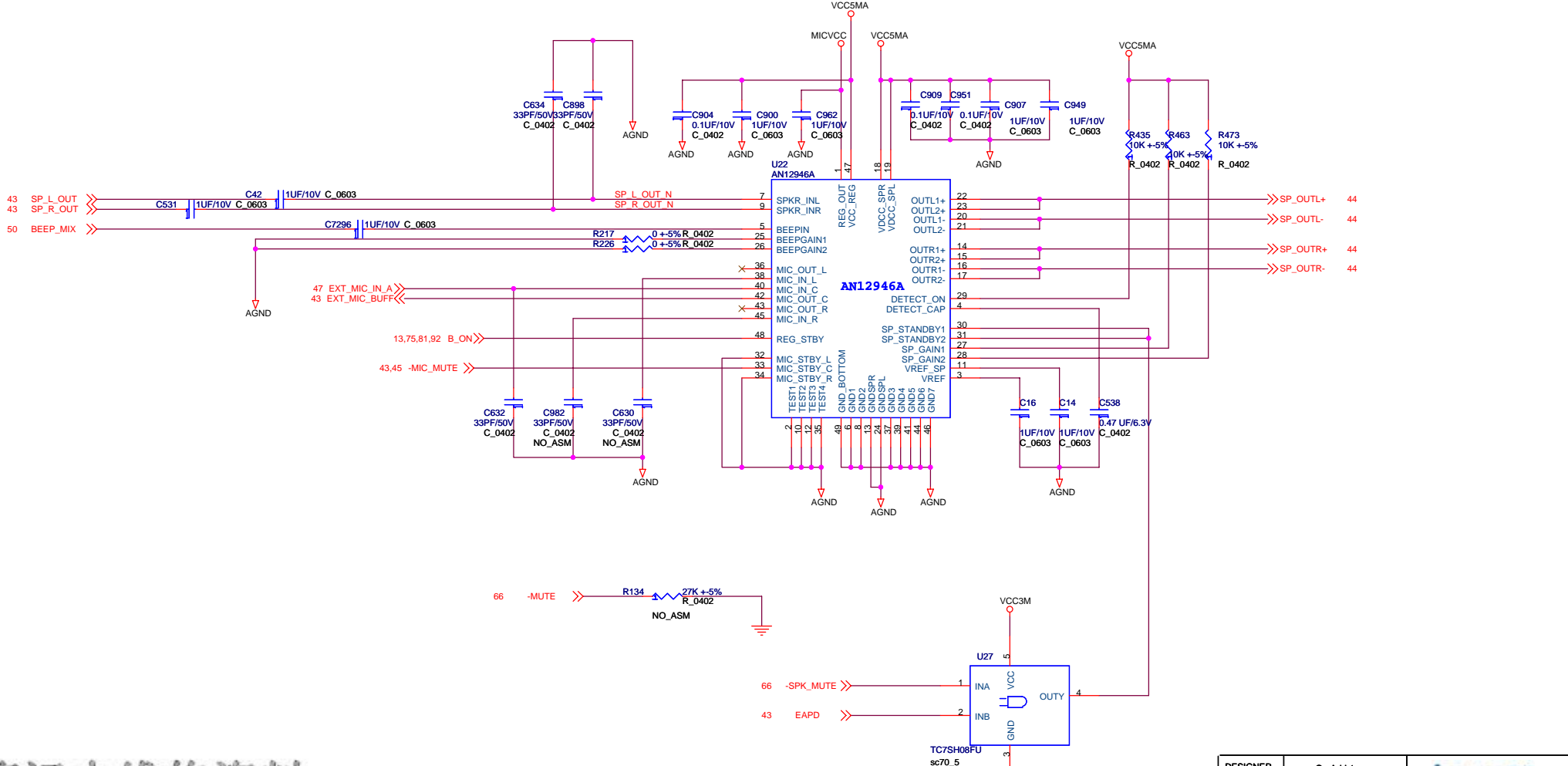
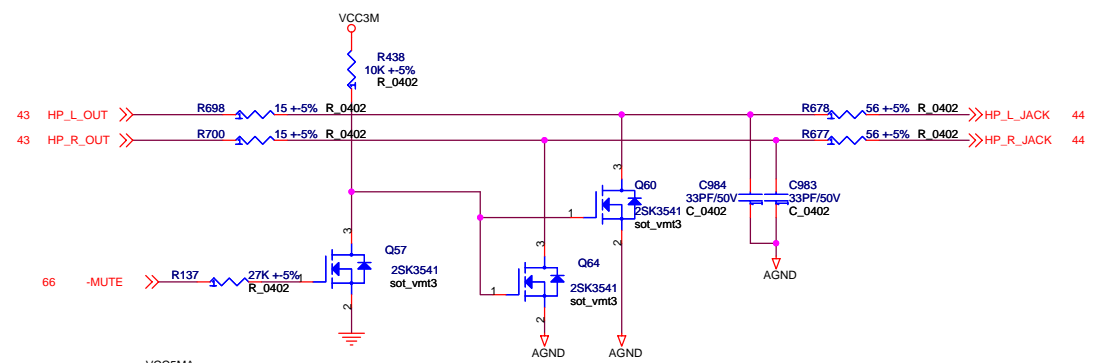
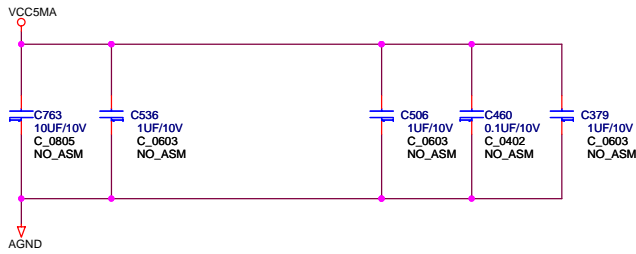

笔记本维修资料 <http://shop36609371.taobao.com>
 QQ:52643956

DESIGNER	<OrgAddr1>	
CHECKED	<OrgAddr2>	
APPROVED	<OrgAddr3>	Part No. 42X7359
CLASS	<OrgAddr4>	EC No. L52888
THIS DOCUMENT IS THE PROPERTY OF LENOVO. ITS USE IS AUTHORIZED ONLY FOR RESPONDING TO A REQUEST FOR QUOTATION OR FOR THE PERFORMANCE OF WORK FOR LENOVO. ALL QUESTIONS MUST BE REFERRED TO THE LENOVO PURCHASING DEPARTMENT.		TITLE: Kodach2 Ver: PDV
LENOVO CONFIDENTIAL		AUDIO HDP AMP
		sheet 49 of 102
		Tuesday, October 30, 2007

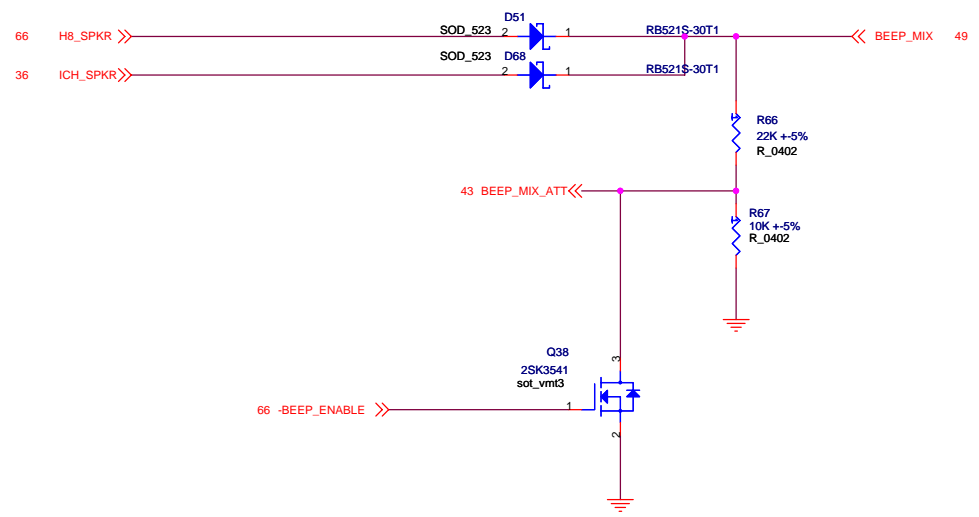

笔记本维修资料 <http://shop36609371.taobao.com>
 QQ:52643956

DESIGNER	<OrgAddr1>	lenovo 联想
CHECKED	<OrgAddr2>	
APPROVED	<OrgAddr3>	Part No . 42X7359
CLASS	<OrgAddr4>	EC No . L52888
<small>THIS DOCUMENT IS THE PROPERTY OF LENOVO. ITS USE IS AUTHORIZED ONLY FOR RESPONDING TO A REQUEST FOR QUOTATION OR FOR THE PERFORMANCE OF WORK FOR LENOVO. ALL QUESTIONS MUST BE REFERRED TO THE LENOVO PURCHASING DEPARTMENT.</small>		TITLE: Kodachi2 Ver: PDV
		AUDIO HDP BEEP
LENOVO CONFIDENTIAL		sheet 50 of 102 Tuesday, October 30, 2007

BLANK PAGE

笔记本维修资料 <http://shop36609371.taobao.com>

QQ:52643956

DESIGNER	<OrgAddr1>	
CHECKED	<OrgAddr2>	
APPROVED	<OrgAddr3>	Part No . 42X7359
CLASS	<OrgAddr4>	EC No . L52888
<small>THIS DOCUMENT IS THE PROPERTY OF LENOVO. ITS USE IS AUTHORIZED ONLY FOR RESPONDING TO A REQUEST FOR QUOTATION OR FOR THE PERFORMANCE OF WORK FOR LENOVO. ALL QUESTIONS MUST BE REFERRED TO THE LENOVO PURCHASING DEPARTMENT.</small>		TITLE: Kodachi2 Ver: PDV
LENOVO CONFIDENTIAL		sheet 51 of 102 Tuesday, October 30, 2007

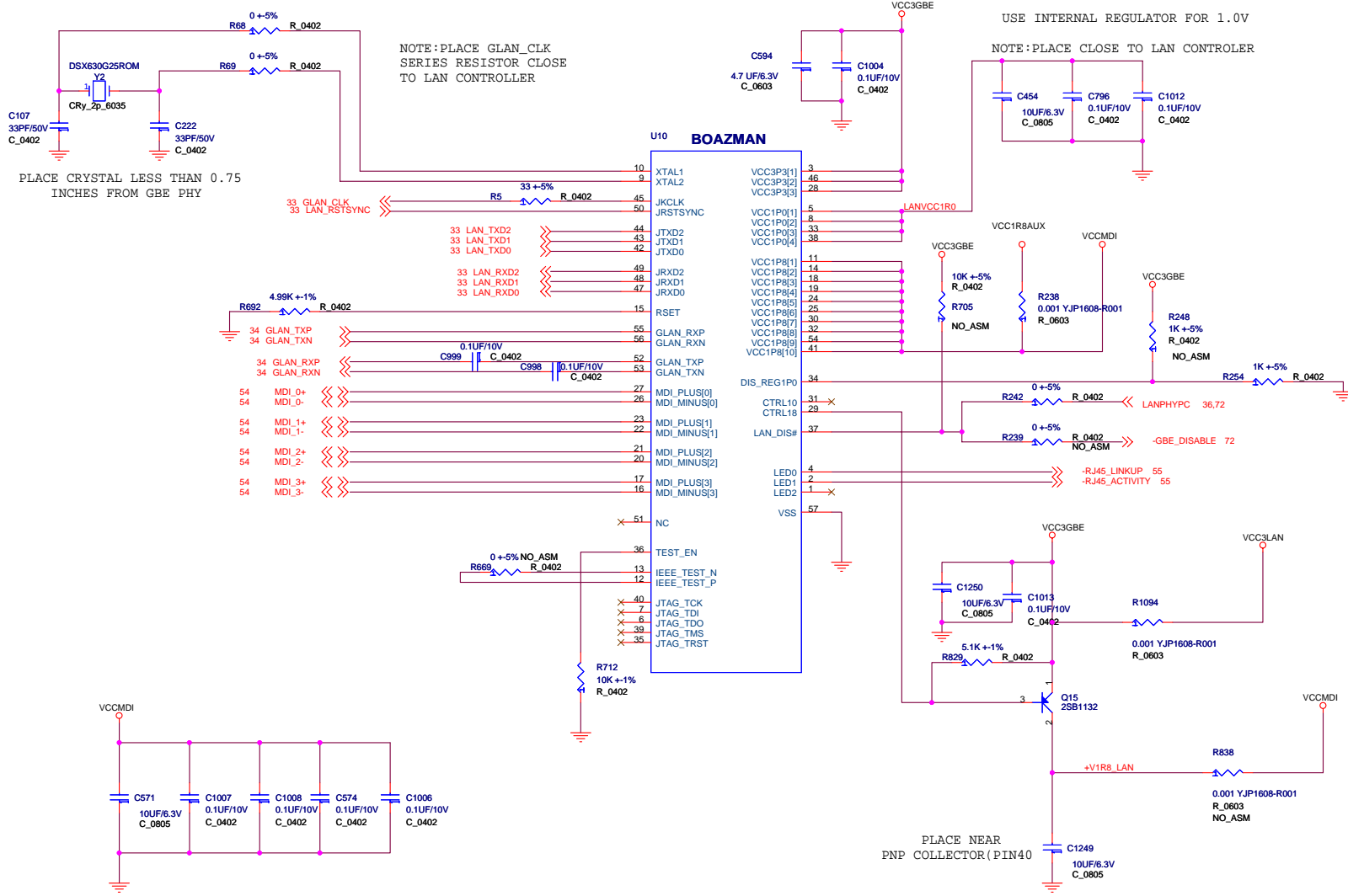

笔记本维修资料 <http://shop36609371.taobao.com>
 QQ:52643956

DESIGNER	<OrgAddr1>	
CHECKED	<OrgAddr2>	
APPROVED	<OrgAddr3>	
CLASS	<OrgAddr4>	Part No. 42X7359
THIS DOCUMENT IS THE PROPERTY OF LENOVO. ITS USE IS AUTHORIZED ONLY FOR RESPONDING TO A REQUEST FOR QUOTATION OR FOR THE PERFORMANCE OF WORK FOR LENOVO. ALL QUESTIONS MUST BE REFERRED TO THE LENOVO PURCHASE DEPARTMENT.		EC No. L52888
LENOVO CONFIDENTIAL		TITLE: Kodachi2 Ver: PDV GBE BOAZMAN
		sheet 52 of 102 Tuesday, October 30, 2007

笔记本维修资料 <http://shop36609371.taobao.com>

QQ:52643956

DESIGNER	<OrgAddr1>		
CHECKED	<OrgAddr2>		
APPROVED	<OrgAddr3>		Part No . 42X7359
CLASS	<OrgAddr4>		EC No . L52888
<small>THIS DOCUMENT IS THE PROPERTY OF LENOVO. ITS USE IS AUTHORIZED ONLY FOR RESPONDING TO A REQUEST FOR QUOTATION OR FOR THE PERFORMANCE OF WORK FOR LENOVO. ALL QUESTIONS MUST BE REFERRED TO THE LENOVO PURCHASING DEPARTMENT.</small>		TITLE: Kodachi2 Ver: PDV	
LENOVO CONFIDENTIAL		sheet 53 of 102 Tuesday, October 30, 2007	

VCCMDI

The trace width should be wider than 35mil. Please use PTH normal via(22mil),if possible.

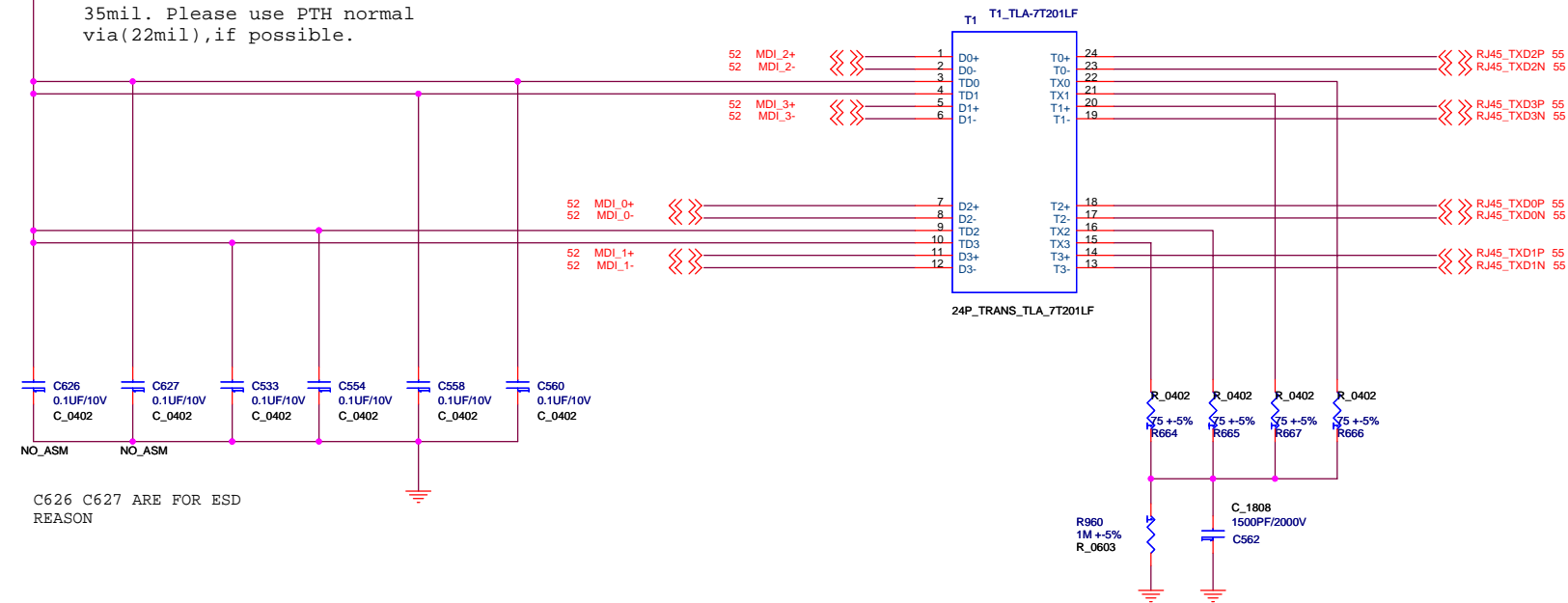

笔记本维修资料 <http://shop36609371.taobao.com>

QQ:52643956

DESIGNER	<OrgAddr1>	
CHECKED	<OrgAddr2>	
APPROVED	<OrgAddr3>	Part No. 42X7359
CLASS	<OrgAddr4>	EC No. L52888
THIS DOCUMENT IS THE PROPERTY OF LENOVO. ITS USE IS AUTHORIZED ONLY FOR RESPONDING TO A REQUEST FOR QUOTATION OR FOR THE PERFORMANCE OF WORK FOR LENOVO. ALL QUESTIONS MUST BE REFERRED TO THE LENOVO PURCHASING DEPARTMENT.		TITLE: Kodachi2 Ver: PDV
LENOVO CONFIDENTIAL		GBE MAGNETICS
		sheet 54 of 102 Tuesday, October 30, 2007

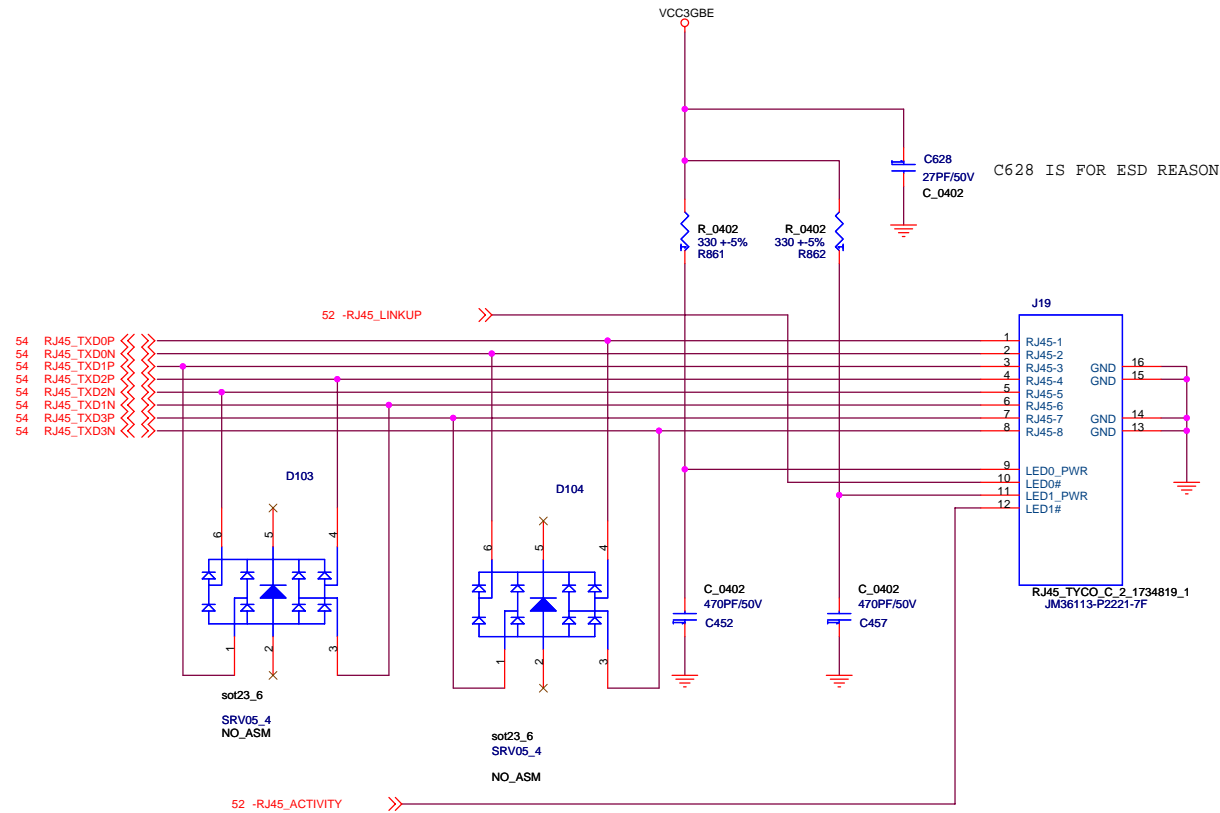

笔记本维修资料 <http://shop36609371.taobao.com>
 QQ:52643956

DESIGNER	<OrgAddr1>	lenovo 联想
CHECKED	<OrgAddr2>	
APPROVED	<OrgAddr3>	Part No . 42X7359
CLASS	<OrgAddr4>	EC No . L52888
THIS DOCUMENT IS THE PROPERTY OF LENOVO. ITS USE IS AUTHORIZED ONLY FOR RESPONDING TO A REQUEST FOR QUOTATION OR FOR THE PERFORMANCE OF WORK FOR LENOVO. ALL QUESTIONS MUST BE REFERRED TO THE LENOVO PURCHASING DEPARTMENT.		TITLE: Kodachi2 Ver: PDV
		RJ45 CONN
LENOVO CONFIDENTIAL		sheet 55 of 102 Tuesday, October 30, 2007

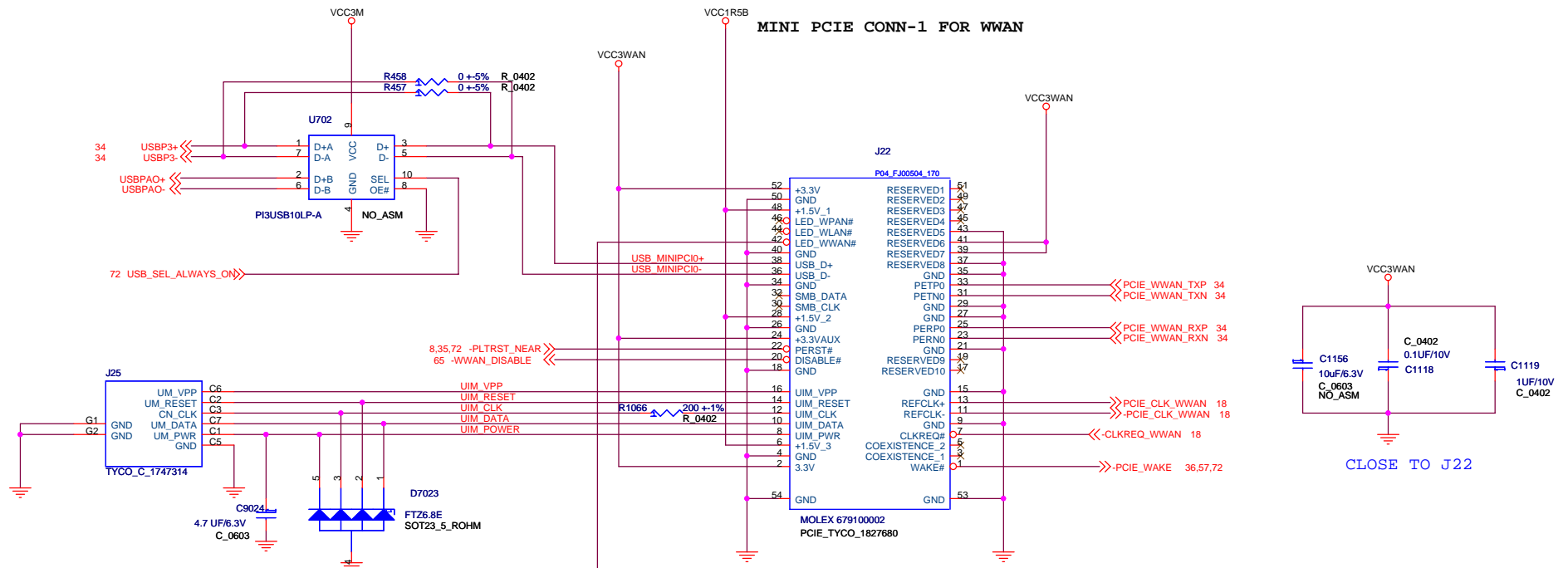

NOTE: UMI_POWER NET need 20 mil width.
 NOTE: Please put FTZ6.8E near SIM Connector

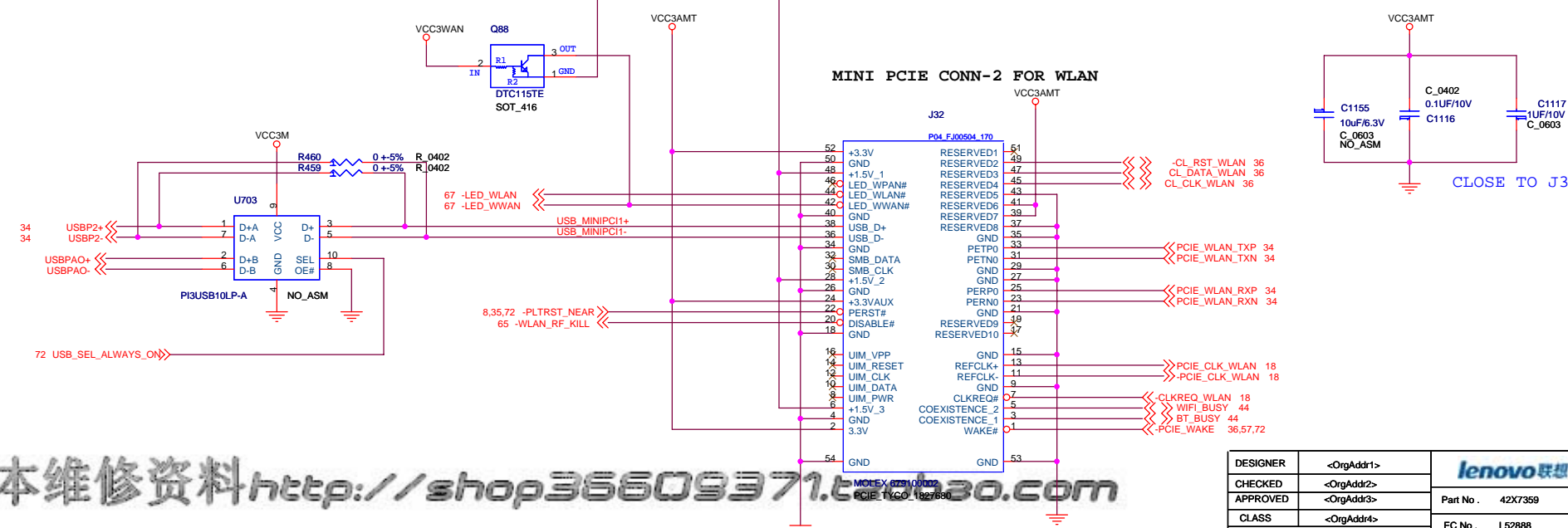

笔记本维修资料 <http://shop36609371.taobao.com>
 QQ:52643956

DESIGNER	<OrgAddr1>	
CHECKED	<OrgAddr2>	
APPROVED	<OrgAddr3>	Part No. 42X7359
CLASS	<OrgAddr4>	EC No. L52888
THIS DOCUMENT IS THE PROPERTY OF LENOVO. ITS USE IS AUTHORIZED ONLY FOR RESPONDING TO A REQUEST FOR QUOTATION OR FOR THE PERFORMANCE OF WORK FOR LENOVO. ALL QUESTIONS MUST BE REFERRED TO THE LENOVO PURCHASING DEPARTMENT.		
		TITLE: Kodachi2 Ver: PDV
		MINI PCIE SLOT(WWAN/WLAN)
		sheet 56 of 102
		Tuesday, October 30, 2007
LENOVO CONFIDENTIAL		

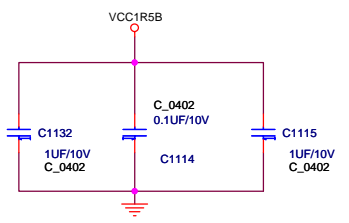
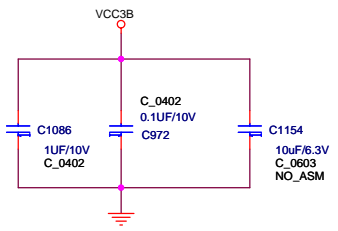
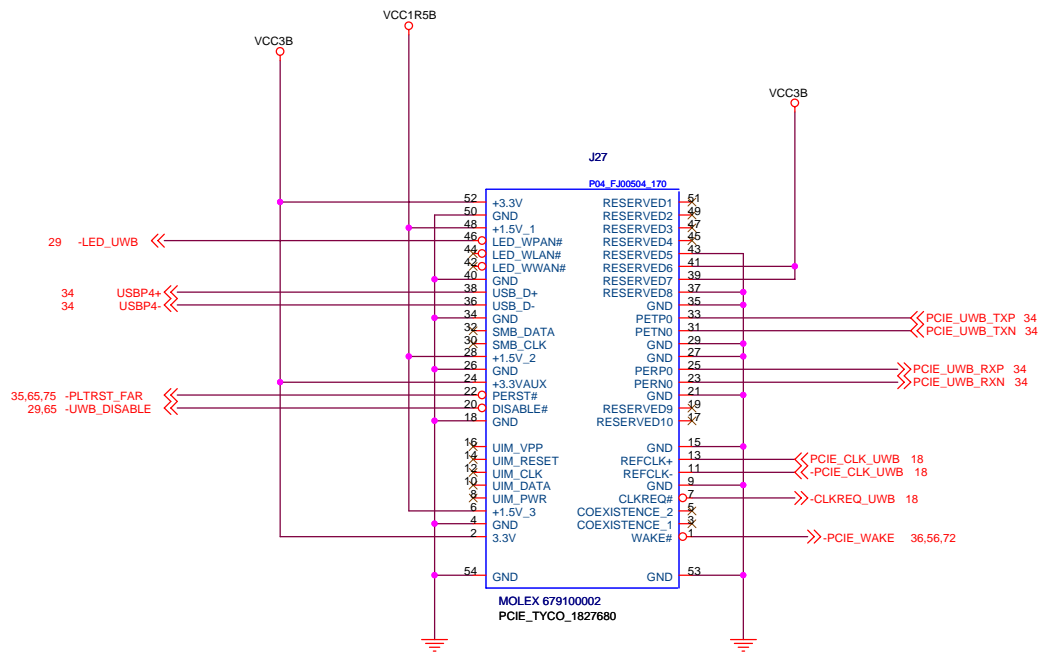

笔记本维修资料 <http://shop36609371.taobao.com>

QQ:52643956

DESIGNER	<OrgAddr1>	lenovo 联想
CHECKED	<OrgAddr2>	
APPROVED	<OrgAddr3>	Part No. 42X7359
CLASS	<OrgAddr4>	EC No. L52888
THIS DOCUMENT IS THE PROPERTY OF LENOVO. ITS USE IS AUTHORIZED ONLY FOR RESPONDING TO A REQUEST FOR QUOTATION OR FOR THE PERFORMANCE OF WORK FOR LENOVO. ALL QUESTIONS MUST BE REFERRED TO THE LENOVO PURCHASING DEPARTMENT.		TITLE: Kodachi2 Ver: PDV
		MICRO PCIE CONN
LENOVO CONFIDENTIAL		sheet 57 of 102 Tuesday, October 30, 2007

BLANK PAGE

笔记本维修资料 <http://shop36609371.taobao.com>

QQ:52643956

DESIGNER	<OrgAddr1>	
CHECKED	<OrgAddr2>	
APPROVED	<OrgAddr3>	Part No . 42X7359
CLASS	<OrgAddr4>	EC No . L52888
<small>THIS DOCUMENT IS THE PROPERTY OF LENOVO. ITS USE IS AUTHORIZED ONLY FOR RESPONDING TO A REQUEST FOR QUOTATION OR FOR THE PERFORMANCE OF WORK FOR LENOVO. ALL QUESTIONS MUST BE REFERRED TO THE LENOVO PURCHASING DEPARTMENT.</small>		TITLE: Kodachi2 Ver: PDV
LENOVO CONFIDENTIAL		sheet 58 of 102 Tuesday, October 30, 2007

BLANK PAGE

笔记本维修资料 <http://shop36609371.taobao.com>

QQ:52643956

DESIGNER	<OrgAddr1>	
CHECKED	<OrgAddr2>	
APPROVED	<OrgAddr3>	Part No . 42X7359
CLASS	<OrgAddr4>	EC No . L52888
<small>THIS DOCUMENT IS THE PROPERTY OF LENOVO. ITS USE IS AUTHORIZED ONLY FOR RESPONDING TO A REQUEST FOR QUOTATION OR FOR THE PERFORMANCE OF WORK FOR LENOVO. ALL QUESTIONS MUST BE REFERRED TO THE LENOVO PURCHASING DEPARTMENT.</small>		TITLE: Kodachi2 Ver: PDV
LENOVO CONFIDENTIAL		sheet 59 of 102 Tuesday, October 30, 2007

BLANK PAGE

笔记本维修资料 <http://shop36609371.taobao.com>

QQ:52643956

DESIGNER	<OrgAddr1>	
CHECKED	<OrgAddr2>	
APPROVED	<OrgAddr3>	Part No . 42X7359
CLASS	<OrgAddr4>	EC No . L52888
<small>THIS DOCUMENT IS THE PROPERTY OF LENOVO. ITS USE IS AUTHORIZED ONLY FOR RESPONDING TO A REQUEST FOR QUOTATION OR FOR THE PERFORMANCE OF WORK FOR LENOVO. ALL QUESTIONS MUST BE REFERRED TO THE LENOVO PURCHASING DEPARTMENT.</small>		TITLE: Kodachi2 Ver: PDV
LENOVO CONFIDENTIAL		EXPRESS CARD
		sheet 60 of 102 Tuesday, October 30, 2007

BLANK PAGE

笔记本维修资料 <http://shop36609371.taobao.com>

QQ:52643956

DESIGNER	<OrgAddr1>	
CHECKED	<OrgAddr2>	
APPROVED	<OrgAddr3>	Part No . 42X7359
CLASS	<OrgAddr4>	EC No . L52888
<small>THIS DOCUMENT IS THE PROPERTY OF LENOVO. ITS USE IS AUTHORIZED ONLY FOR RESPONDING TO A REQUEST FOR QUOTATION OR FOR THE PERFORMANCE OF WORK FOR LENOVO. ALL QUESTIONS MUST BE REFERRED TO THE LENOVO PURCHASING DEPARTMENT.</small>		TITLE: Kodachi2 Ver: PDV
LENOVO CONFIDENTIAL		sheet 61 of 102 Tuesday, October 30, 2007

BLANK PAGE

笔记本维修资料 <http://shop36609371.taobao.com>

QQ:52643956

DESIGNER	<OrgAddr1>		
CHECKED	<OrgAddr2>		
APPROVED	<OrgAddr3>		Part No . 42X7359
CLASS	<OrgAddr4>		EC No . L52888
<small>THIS DOCUMENT IS THE PROPERTY OF LENOVO. ITS USE IS AUTHORIZED ONLY FOR RESPONDING TO A REQUEST FOR QUOTATION OR FOR THE PERFORMANCE OF WORK FOR LENOVO. ALL QUESTIONS MUST BE REFERRED TO THE LENOVO PURCHASING DEPARTMENT.</small>		TITLE: Kodachi2 Ver: PDV	
		BLANKJ	
LENOVO CONFIDENTIAL		sheet 62 of 102 Tuesday, October 30, 2007	

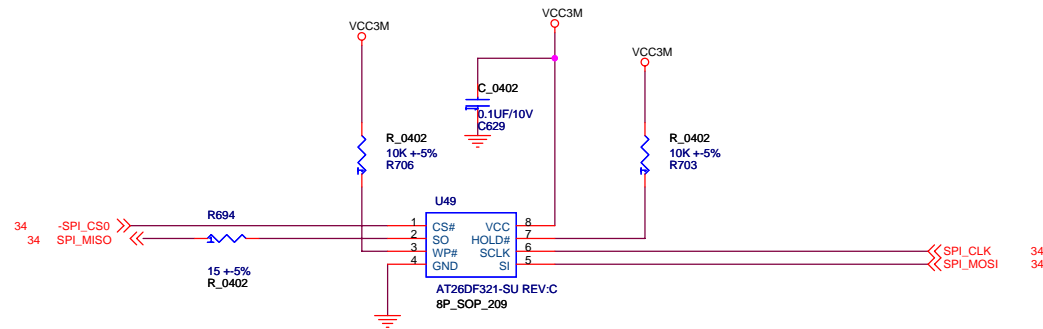

Do not place via under U49

笔记本维修资料 <http://shop36609371.taobao.com>
 QQ:52643956

DESIGNER	<OrgAddr1>	lenovo 联想
CHECKED	<OrgAddr2>	
APPROVED	<OrgAddr3>	Part No . 42X7359
CLASS	<OrgAddr4>	EC No . L52888
THIS DOCUMENT IS THE PROPERTY OF LENOVO. ITS USE IS AUTHORIZED ONLY FOR RESPONDING TO A REQUEST FOR QUOTATION OR FOR THE PERFORMANCE OF WORK FOR LENOVO. ALL QUESTIONS MUST BE REFERRED TO THE LENOVO PURCHASING DEPARTMENT.		TITLE: Kodachi2 Ver: PDV
LENOVO CONFIDENTIAL		EEPROM/FLASH/SHARED
		sheet 63 of 102 Tuesday, October 30, 2007

BLANK PAGE

笔记本维修资料 <http://shop36609371.taobao.com>

QQ:52643956

DESIGNER	<OrgAddr1>		
CHECKED	<OrgAddr2>		
APPROVED	<OrgAddr3>		Part No . 42X7359
CLASS	<OrgAddr4>		EC No . L52888
<small>THIS DOCUMENT IS THE PROPERTY OF LENOVO. ITS USE IS AUTHORIZED ONLY FOR RESPONDING TO A REQUEST FOR QUOTATION OR FOR THE PERFORMANCE OF WORK FOR LENOVO. ALL QUESTIONS MUST BE REFERRED TO THE LENOVO PURCHASING DEPARTMENT.</small>		TITLE: Kodachi2 Ver: PDV	
LENOVO CONFIDENTIAL		sheet 64 of 102 Tuesday, October 30, 2007	

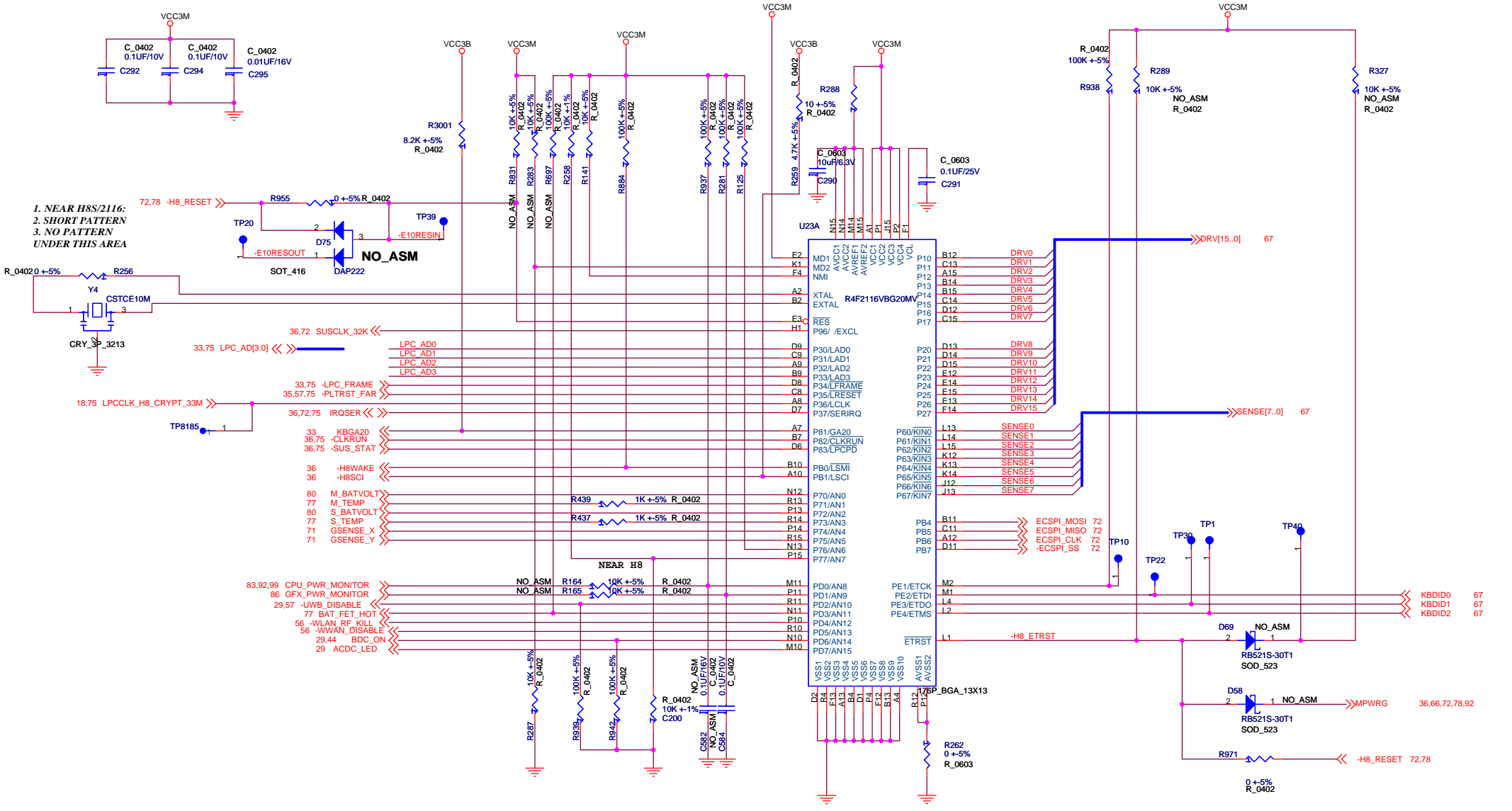

1. NEAR H8S/2116:
2. SHORT PATTERN
3. NO PATTERN
UNDER THIS AREA

NO_ASM

E10A DEBUG I/F	ENABLE	DISABLE(FINAL LOGIC)
R955	NO_ASM	ASM
R971	NO_ASM	ASM
D508	ASM	NO_ASM
R929	ASM	NO_ASM
D751	ASM	NO_ASM
R933	ASM	NO_ASM
R928	ASM	NO_ASM
R908	NO_ASM	ASM
R908	NO_ASM	ASM
R908	NO_ASM	ASM
R908	NO_ASM	ASM

笔记本维修资料 <http://shop36609371.taobao.com>

QQ:52643956

DESIGNER	<OrgAddr1>	
CHECKED	<OrgAddr2>	
APPROVED	<OrgAddr3>	Part No. 42X7359
CLASS	<OrgAddr4>	EC No. L52888
<small>THIS DOCUMENT IS THE PROPERTY OF LENOVO. ITS USE IS AUTHORIZED ONLY FOR RESPONDING TO A REQUEST FOR QUOTATION OR FOR THE PERFORMANCE OF WORK FOR LENOVO. ALL QUESTIONS MUST BE REFERRED TO THE LENOVO PURCHASING DEPARTMENT.</small>		TITLE: Kodachi2 Ver: PDV
		H8S(1/2)
LENOVO CONFIDENTIAL		sheet 65 of 102 Tuesday, October 30, 2007

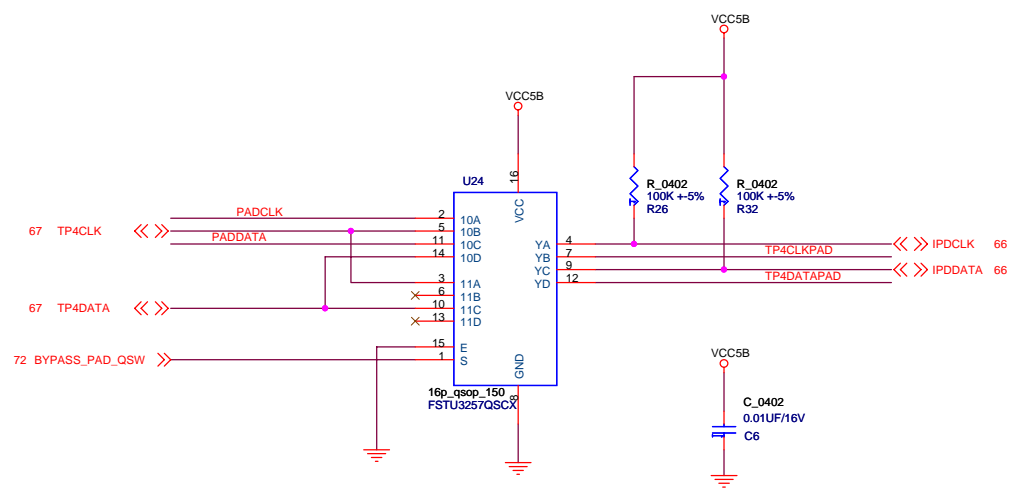
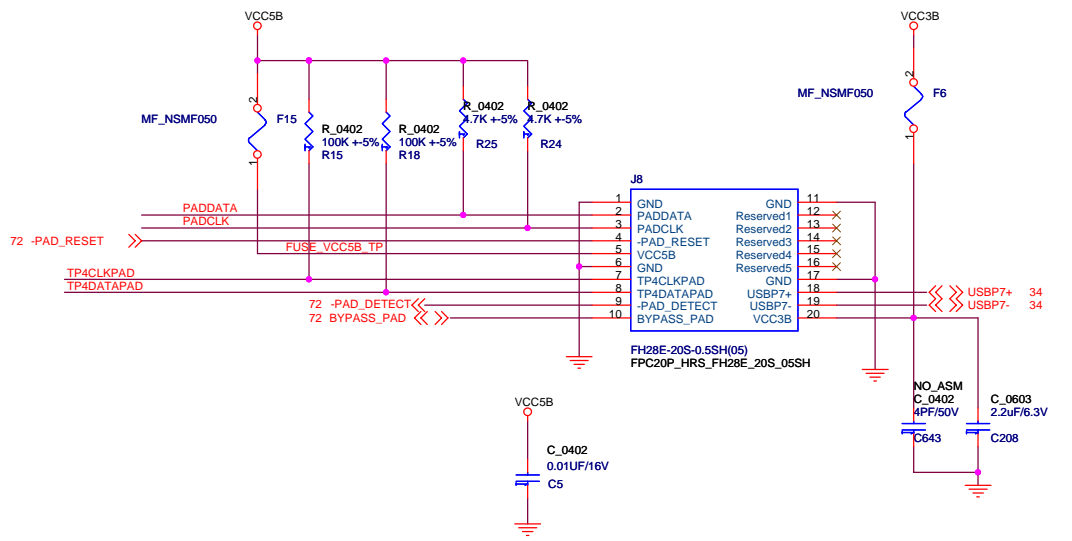

笔记本维修资料 <http://shop36609371.taobao.com>
 QQ:52643956

DESIGNER	<OrgAddr1>	lenovo 联想
CHECKED	<OrgAddr2>	
APPROVED	<OrgAddr3>	Part No. 42X7359
CLASS	<OrgAddr4>	EC No. L52888
THIS DOCUMENT IS THE PROPERTY OF LENOVO. ITS USE IS AUTHORIZED ONLY FOR RESPONDING TO A REQUEST FOR QUOTATION OR FOR THE PERFORMANCE OF WORK FOR LENOVO. ALL QUESTIONS MUST BE REFERRED TO THE LENOVO PURCHASING DEPARTMENT.		TITLE: Kodachi2 Ver: PDV
		TP CONN
LENOVO CONFIDENTIAL		sheet 68 of 102 Tuesday, October 30, 2007

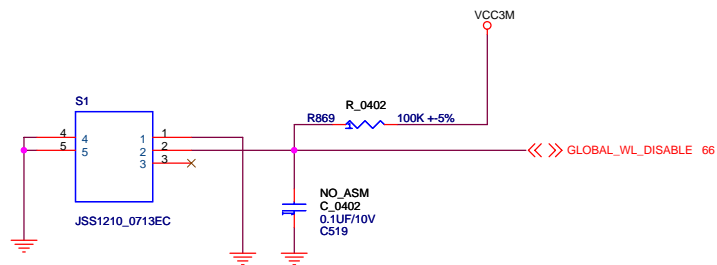

笔记本维修资料 <http://shop36609371.taobao.com>

QQ:52643956

DESIGNER	<OrgAddr1>	lenovo 联想
CHECKED	<OrgAddr2>	
APPROVED	<OrgAddr3>	Part No . 42X7359
CLASS	<OrgAddr4>	EC No . L52888
<small>THIS DOCUMENT IS THE PROPERTY OF LENOVO. ITS USE IS AUTHORIZED ONLY FOR RESPONDING TO A REQUEST FOR QUOTATION OR FOR THE PERFORMANCE OF WORK FOR LENOVO. ALL QUESTIONS MUST BE REFERRED TO THE LENOVO PURCHASING DEPARTMENT.</small>		TITLE: Kodachi2 Ver: PDV
		WIRELESS DISABLE SW
LENOVO CONFIDENTIAL		sheet 69 of 102 Tuesday, October 30, 2007

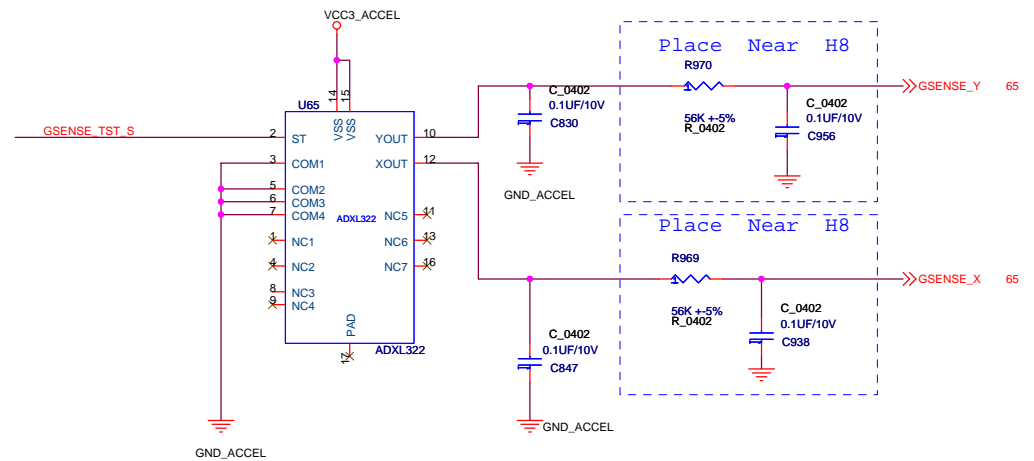
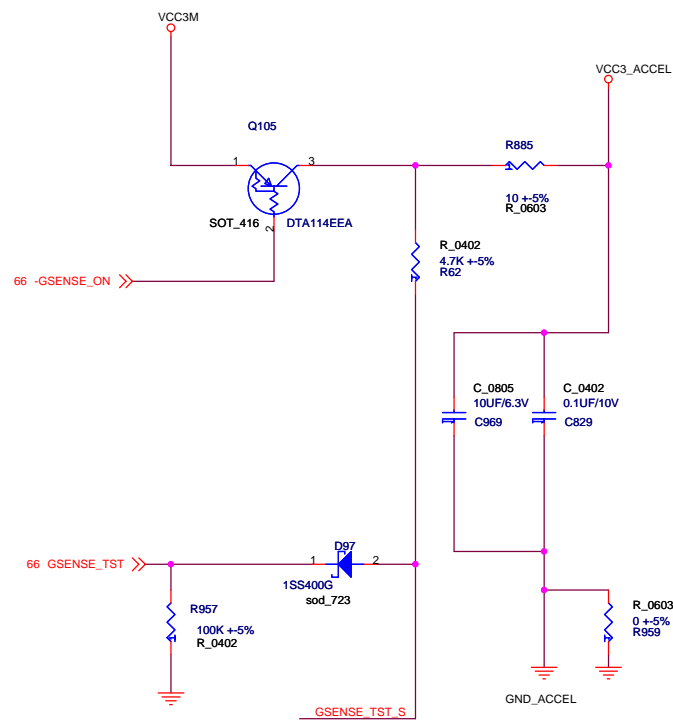

笔记本维修资料 <http://shop36609371.taobao.com>
 QQ:52643956

DESIGNER	<OrgAddr1>	
CHECKED	<OrgAddr2>	
APPROVED	<OrgAddr3>	Part No. 42X7359
CLASS	<OrgAddr4>	EC No. L52888
THIS DOCUMENT IS THE PROPERTY OF LENOVO. ITS USE IS AUTHORIZED ONLY FOR RESPONDING TO A REQUEST FOR QUOTATION OR FOR THE PERFORMANCE OF WORK FOR LENOVO. ALL QUESTIONS MUST BE REFERRED TO THE LENOVO PURCHASING DEPARTMENT.		TITLE: Kodachi2 Ver: PDV
		G-SENSOR
LENOVO CONFIDENTIAL		sheet 71 of 102 Tuesday, October 30, 2007

BLANK PAGE

笔记本维修资料 <http://shop36609371.taobao.com>

QQ:52643956

DESIGNER	<OrgAddr1>		
CHECKED	<OrgAddr2>		
APPROVED	<OrgAddr3>		Part No. 42X7359
CLASS	<OrgAddr4>		EC No. L52888
<small>THIS DOCUMENT IS THE PROPERTY OF LENOVO. ITS USE IS AUTHORIZED ONLY FOR RESPONDING TO A REQUEST FOR QUOTATION OR FOR THE PERFORMANCE OF WORK FOR LENOVO. ALL QUESTIONS MUST BE REFERRED TO THE LENOVO PURCHASING DEPARTMENT.</small>		TITLE: Kodachi2 Ver: PDV	
LENOVO CONFIDENTIAL		sheet 73 of 102 Tuesday, October 30, 2007	

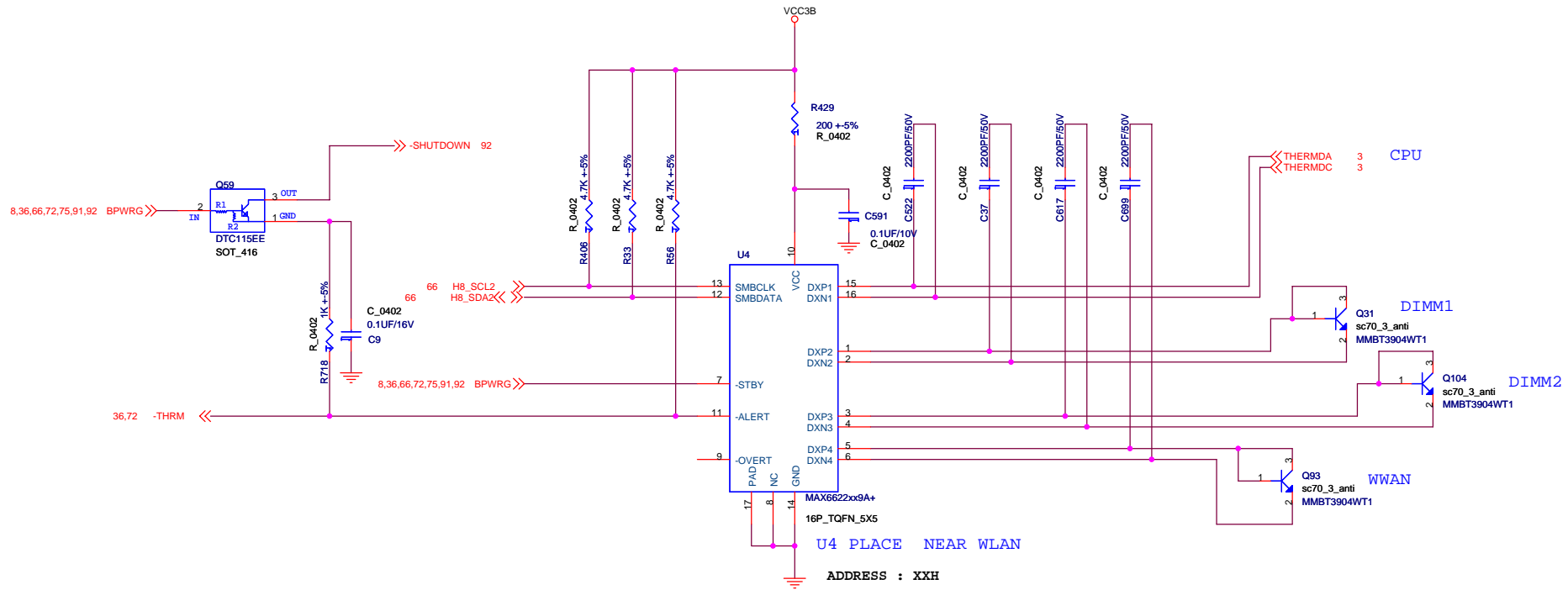

笔记本维修资料 <http://shop36609371.taobao.com>
 QQ:52643956

DESIGNER	<OrgAddr1>	lenovo 联想
CHECKED	<OrgAddr2>	
APPROVED	<OrgAddr3>	Part No. 42X7359
CLASS	<OrgAddr4>	EC No. L52888
THIS DOCUMENT IS THE PROPERTY OF LENOVO. ITS USE IS AUTHORIZED ONLY FOR RESPONDING TO A REQUEST FOR QUOTATION OR FOR THE PERFORMANCE OF WORK FOR LENOVO. ALL QUESTIONS MUST BE REFERRED TO THE LENOVO PURCHASING DEPARTMENT.		TITLE: Kodachi2 Ver: PDV
		THERMAL SENSOR
LENOVO CONFIDENTIAL		sheet 74 of 102 Tuesday, October 30, 2007

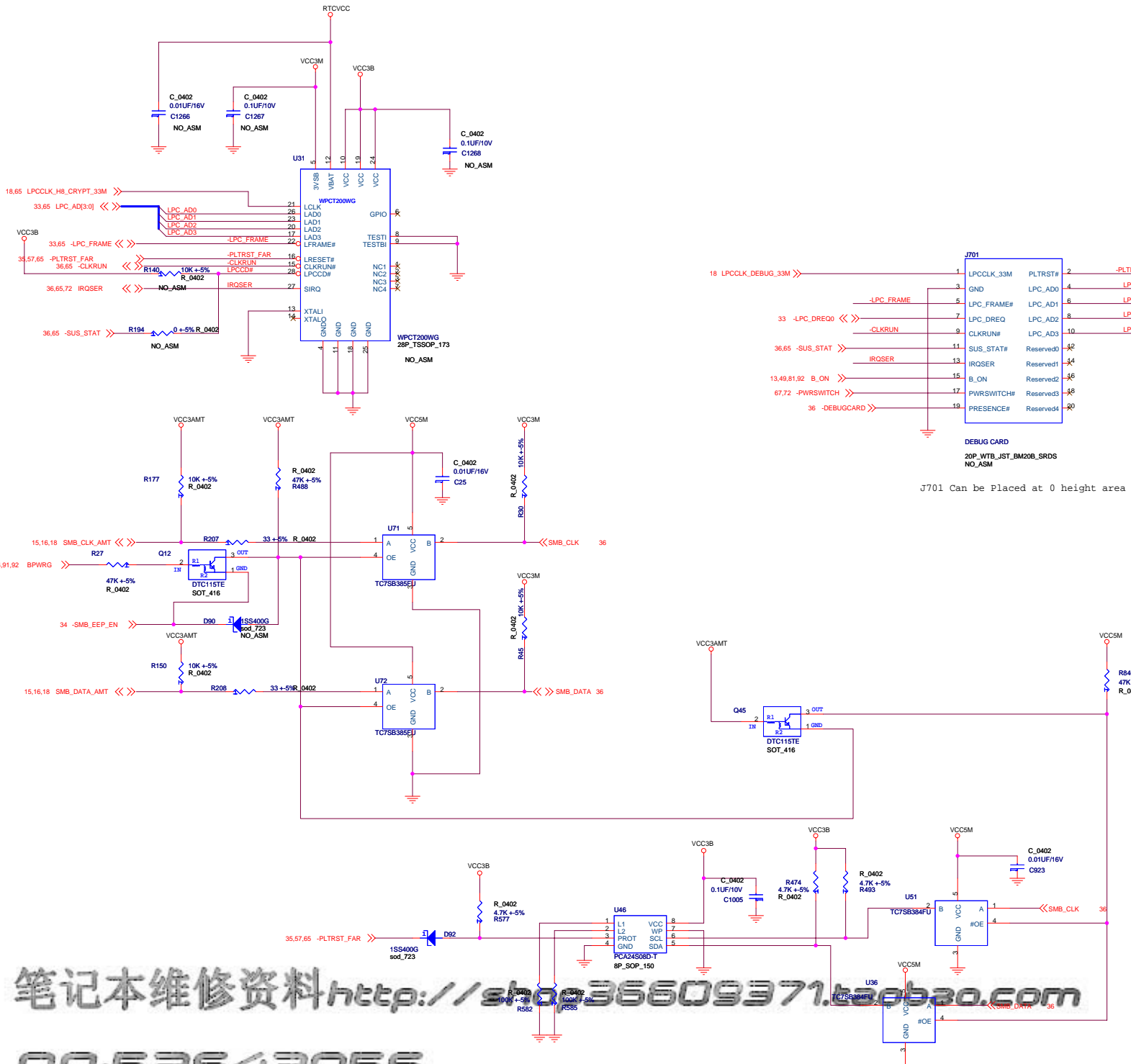

J701 Can be Placed at 0 height area

笔记本维修资料 <http://st.36609371.taobao.com>
 QQ:52643956

DESIGNER	<OrgAddr1>	 Part No. 42X7359 EC No. L52888 TITLE: Kodach2 Ver: PDV I2C BUS/SMBUS sheet 75 of 102 Tuesday, October 30, 2007
CHECKED	<OrgAddr2>	
APPROVED	<OrgAddr3>	
CLASS	<OrgAddr4>	
THIS DOCUMENT IS THE PROPERTY OF LENOVO. ITS USE IS AUTHORIZED ONLY FOR REFERRING TO A REQUEST FOR QUOTATION OR FOR THE PERFORMANCE OF WORK FOR LENOVO. ALL QUESTIONS MUST BE REFERRED TO THE LENOVO PURCHASING DEPARTMENT.		
LENOVO CONFIDENTIAL		

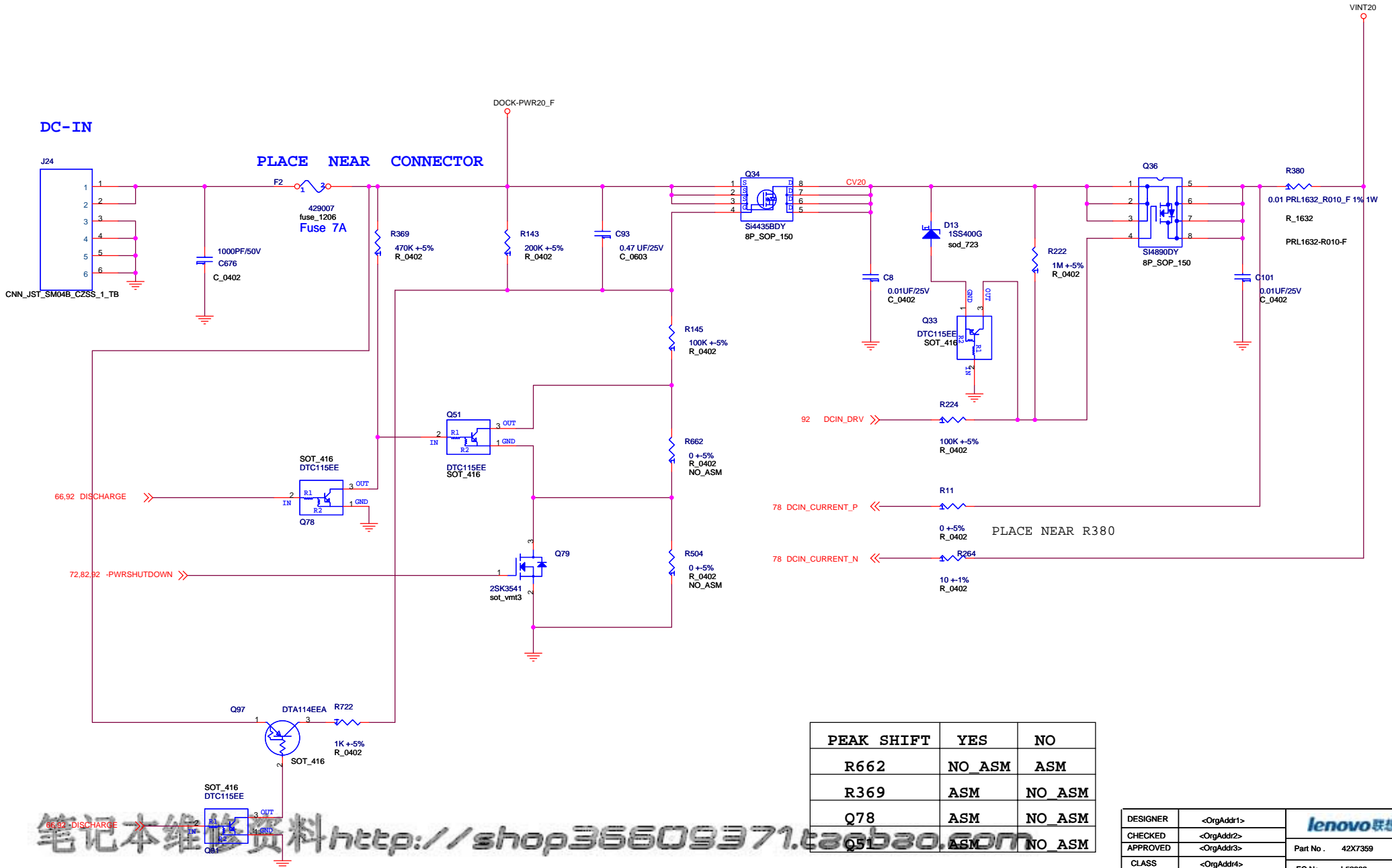

PEAK SHIFT	YES	NO
R662	NO_ASM	ASM
R369	ASM	NO_ASM
Q78	ASM	NO_ASM
Q34	ASM	NO_ASM

DESIGNER	<OrgAddr1>	lenovo 联想
CHECKED	<OrgAddr2>	
APPROVED	<OrgAddr3>	Part No. 42X7359
CLASS	<OrgAddr4>	EC No. L52888
THIS DOCUMENT IS THE PROPERTY OF LENOVO. ITS USE IS AUTHORIZED ONLY FOR RESPONDING TO A REQUEST FOR QUOTATION OR FOR THE PERFORMANCE OF WORK FOR LENOVO. ALL QUESTIONS MUST BE REFERRED TO THE LENOVO PURCHASING DEPARTMENT.		TITLE: Kodachi2 Ver: PDV
		DC-IN
LENOVO CONFIDENTIAL		sheet 76 of 102 Tuesday, October 30, 2007

笔记本维修资料 <http://shop36609371.taobao.com>
QQ:52643956

MAIN BAT CONN

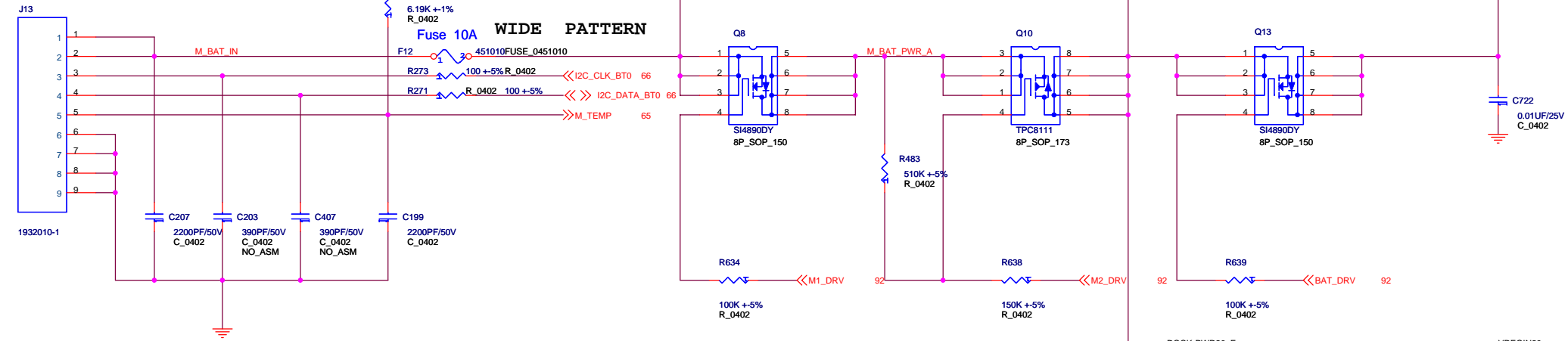

SECOND BAT CONN

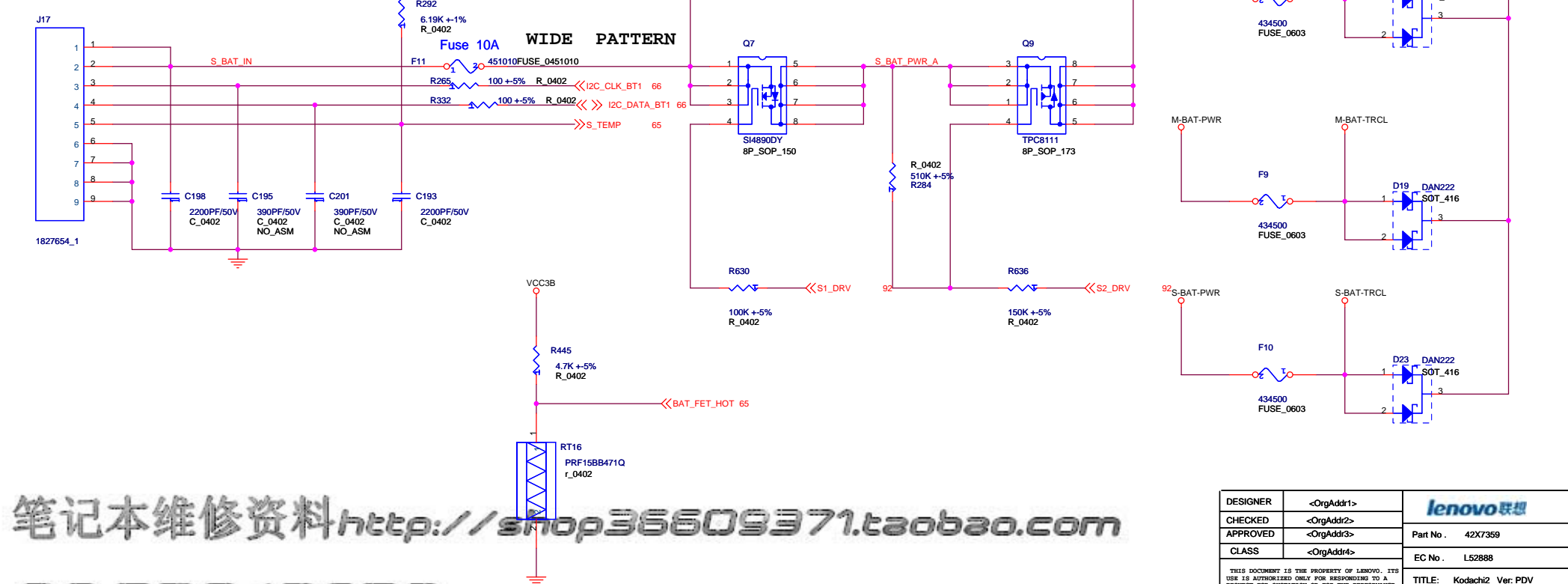

笔记本维修资料 <http://shop36609371.taobao.com>
 QQ:52643956

DESIGNER	<OrgAddr1>	lenovo 联想
CHECKED	<OrgAddr2>	
APPROVED	<OrgAddr3>	Part No. 42X7359
CLASS	<OrgAddr4>	EC No. L52888
THIS DOCUMENT IS THE PROPERTY OF LENOVO. ITS USE IS AUTHORIZED ONLY FOR RESPONDING TO A REQUEST FOR QUOTATION OR FOR THE PERFORMANCE OF WORK FOR LENOVO. ALL QUESTIONS MUST BE REFERRED TO THE LENOVO PURCHASING DEPARTMENT.		TITLE: Kodach2 Ver: PDV
LENOVO CONFIDENTIAL		BATTERY INPUT
		sheet 77 of 102 Tuesday, October 30, 2007

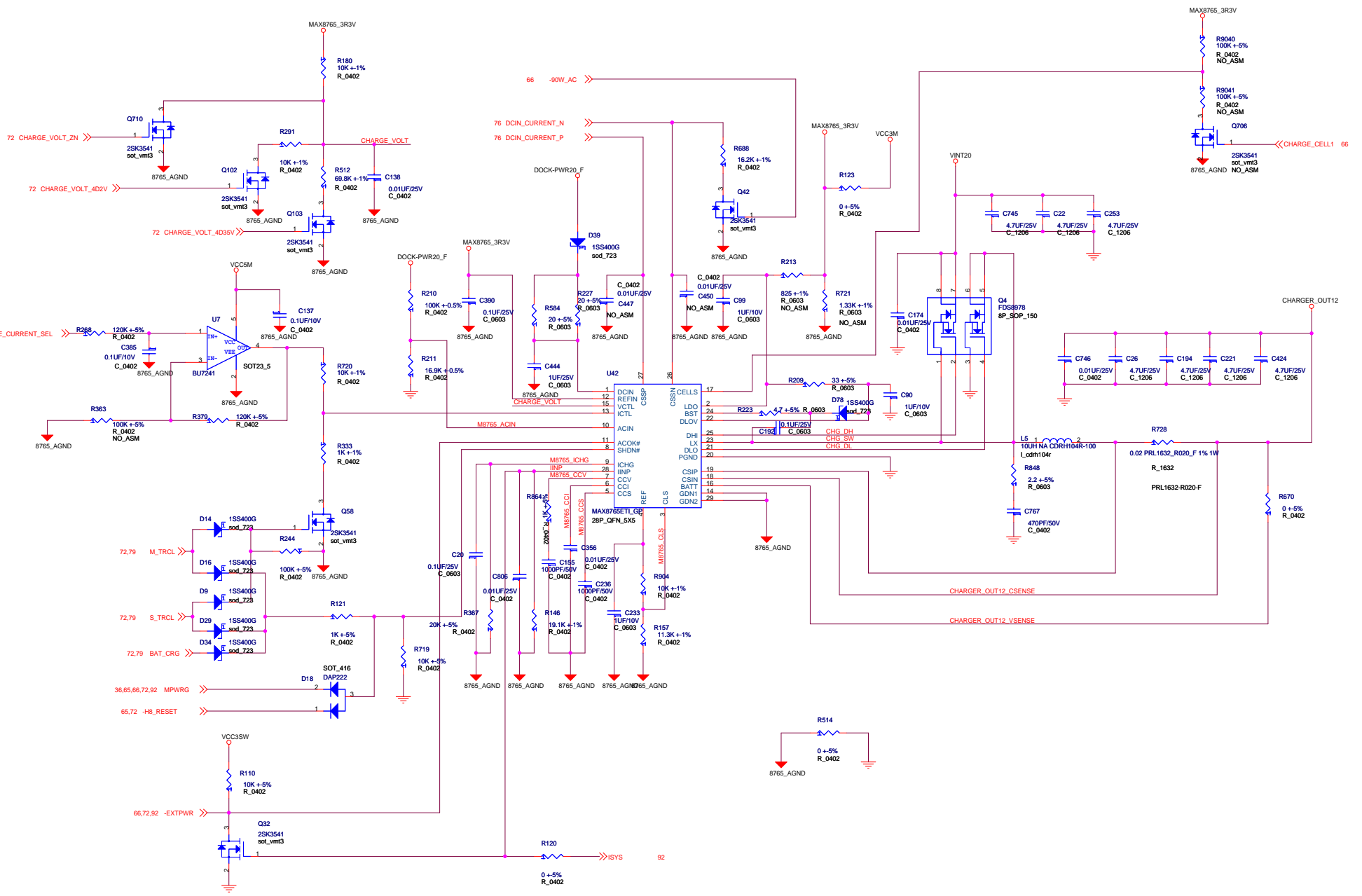

笔记本维修资料 <http://shop36609371.taobao.com>

QQ:52643956

DESIGNER	<OrgAddr1>	lenovo
CHECKED	<OrgAddr2>	
APPROVED	<OrgAddr3>	Part No. 42X7359
CLASS	<OrgAddr4>	EC No. L52888
THIS DOCUMENT IS THE PROPERTY OF LENOVO. ITS USE IS AUTHORIZED ONLY FOR REPAIRING TO A REQUEST FOR QUOTATION OR FOR THE PERFORMANCE OF WORK FOR LENOVO. ALL QUESTIONS MUST BE REFERRED TO THE LENOVO PURCHASING DEPARTMENT.		TITLE: Kodachi2 Ver: PDV
LENOVO CONFIDENTIAL		BATTERY CHARGER(MAX8765)
		sheet 78 of 102
		Tuesday, October 30, 2007

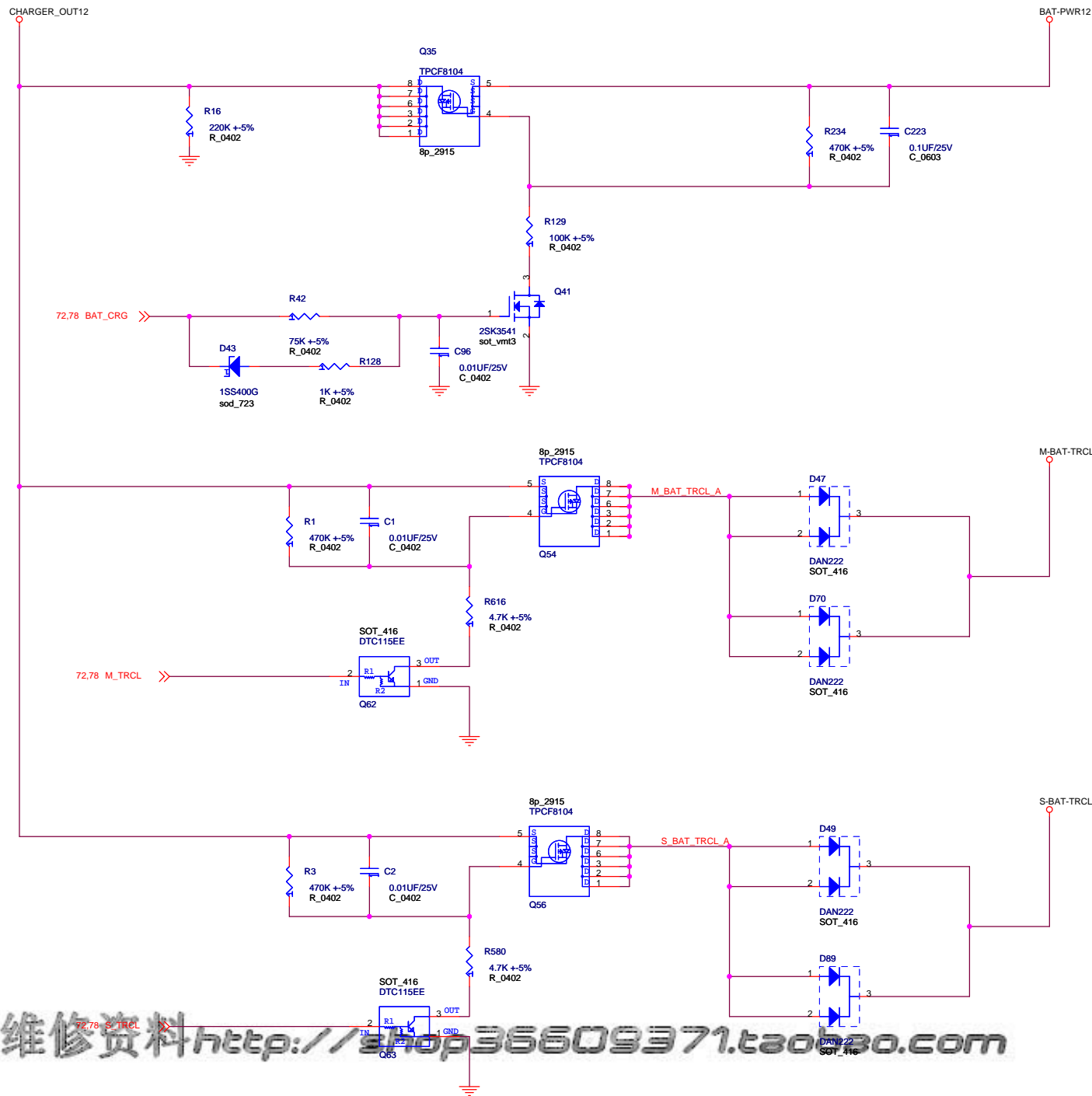

笔记本维修资料 <http://shop36609371.taobao.com>
 QQ:52643956

DESIGNER	<OrgAddr1>	
CHECKED	<OrgAddr2>	
APPROVED	<OrgAddr3>	Part No. 42X7359
CLASS	<OrgAddr4>	EC No. L52888
THIS DOCUMENT IS THE PROPERTY OF LENOVO. ITS USE IS AUTHORIZED ONLY FOR RESPONDING TO A REQUEST FOR QUOTATION OR FOR THE PERFORMANCE OF WORK FOR LENOVO. ALL QUESTIONS MUST BE REFERRED TO THE LENOVO PURCHASING DEPARTMENT.		
TITLE: Kodachi2 Ver: PDV		CHARGE SELECTOR
LENOVO CONFIDENTIAL		sheet 79 of 102 Tuesday, October 30, 2007

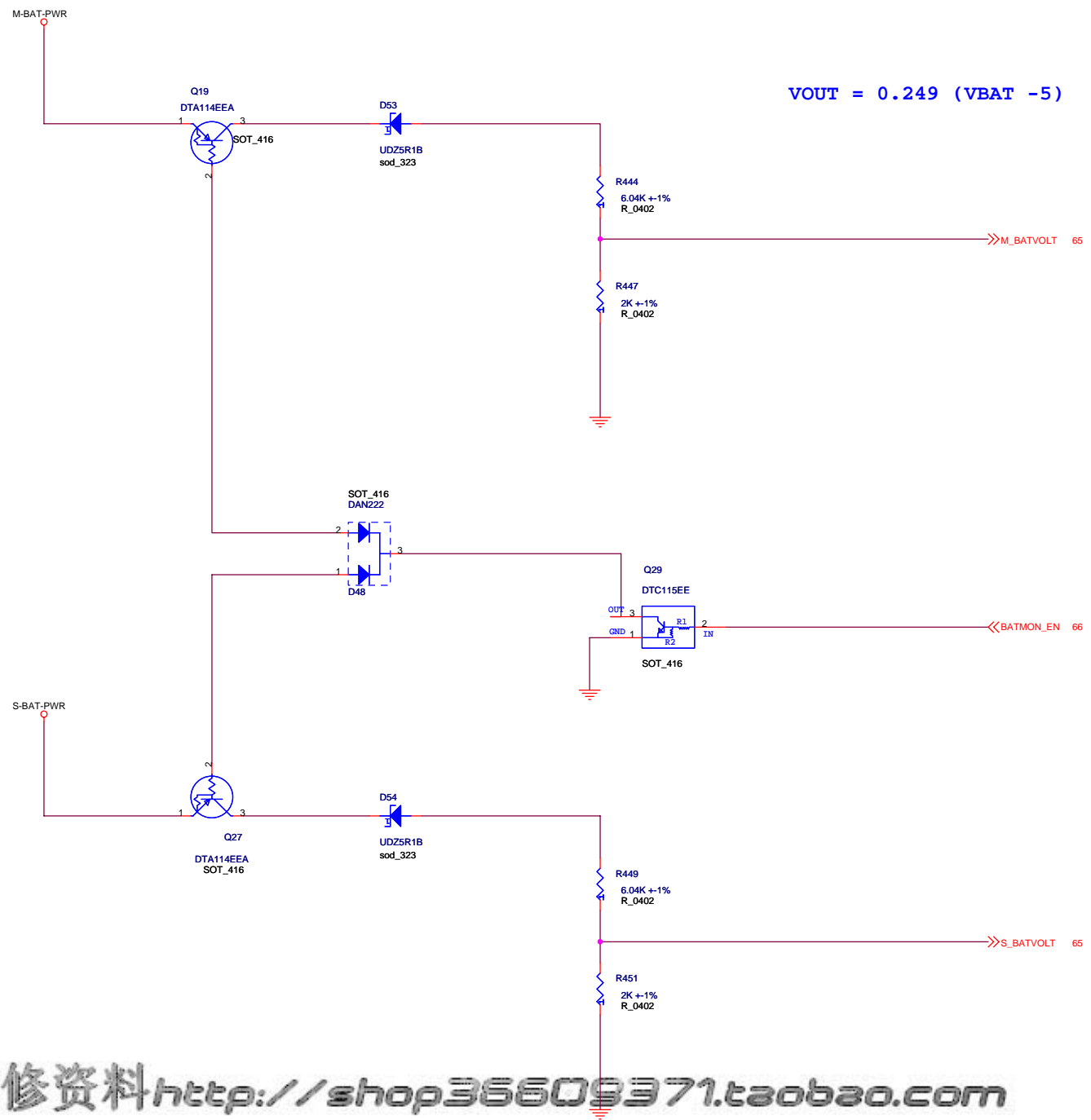

VOUT = 0.249 (VBAT - 5)

笔记本维修资料 <http://shop36609371.taobao.com>
 QQ:52643956

DESIGNER	<OrgAddr1>	 Part No. 42X7359 EC No. L52888 TITLE: Kodachi2 Ver: PDV BATTERY MONITOR sheet 80 of 102 Tuesday, October 30, 2007
CHECKED	<OrgAddr2>	
APPROVED	<OrgAddr3>	
CLASS	<OrgAddr4>	
THIS DOCUMENT IS THE PROPERTY OF LENOVO. ITS USE IS AUTHORIZED ONLY FOR RESPONDING TO A REQUEST FOR QUOTATION OR FOR THE PERFORMANCE OF WORK FOR LENOVO. ALL QUESTIONS MUST BE REFERRED TO THE LENOVO PURCHASING DEPARTMENT.		
LENOVO CONFIDENTIAL		

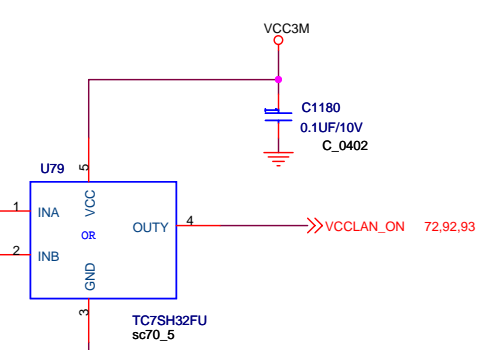
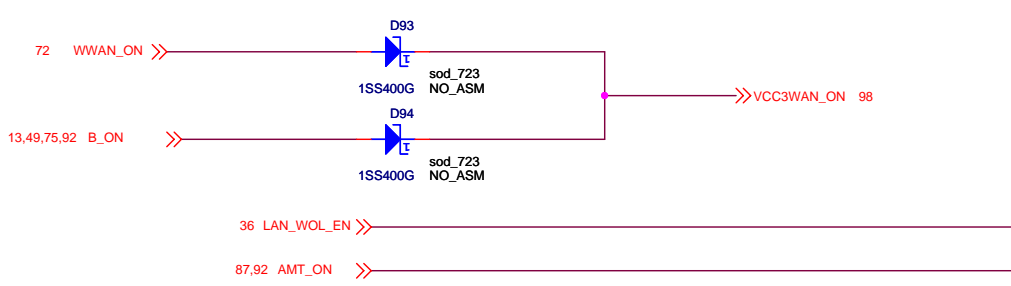
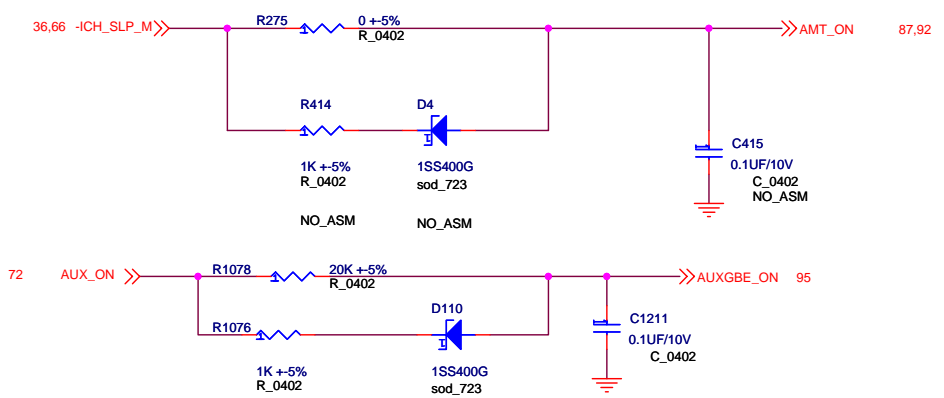
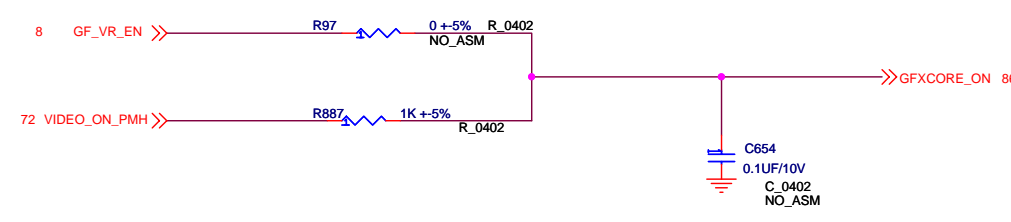
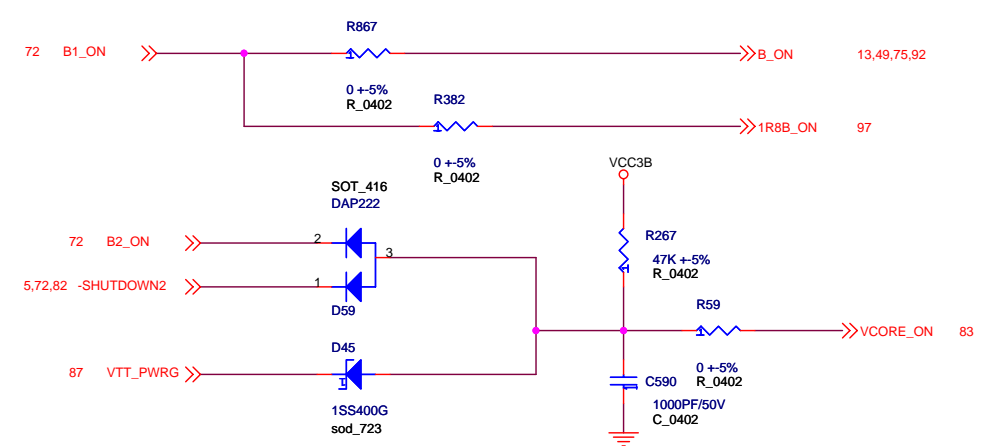
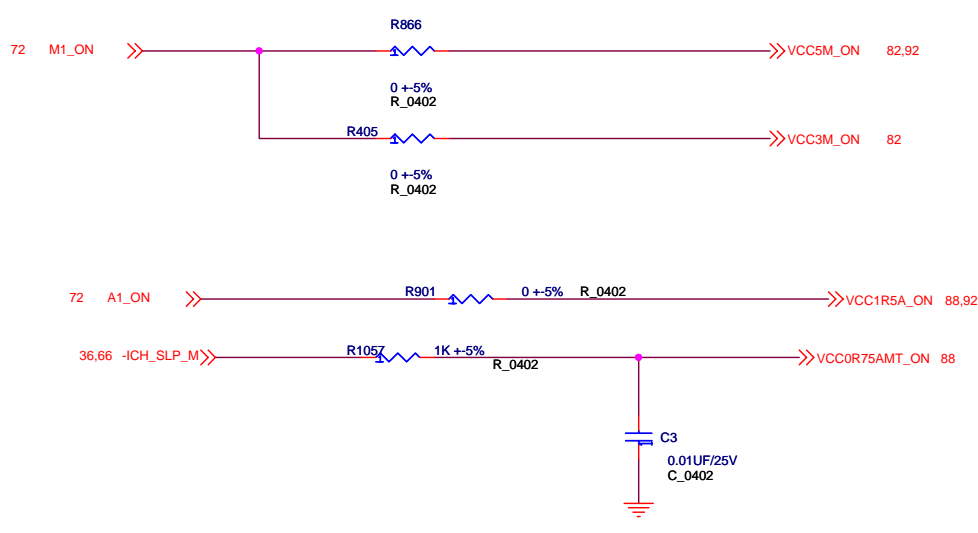

DESIGNER	<OrgAddr1>	lenovo 联想
CHECKED	<OrgAddr2>	
APPROVED	<OrgAddr3>	Part No . 42X7359
CLASS	<OrgAddr4>	EC No . L52888
THIS DOCUMENT IS THE PROPERTY OF LENOVO. ITS USE IS AUTHORIZED ONLY FOR RESPONDING TO A REQUEST FOR QUOTATION OR FOR THE PERFORMANCE OF WORK FOR LENOVO. ALL QUESTIONS MUST BE REFERRED TO THE LENOVO PURCHASING DEPARTMENT.		TITLE: Kodachi2 Ver: PDV
		POWER SEQUENCE
LENOVO CONFIDENTIAL		sheet 81 of 102 Tuesday, October 30, 2007

笔记本维修资料 <http://shop36609371.taobao.com>

QQ:52643956

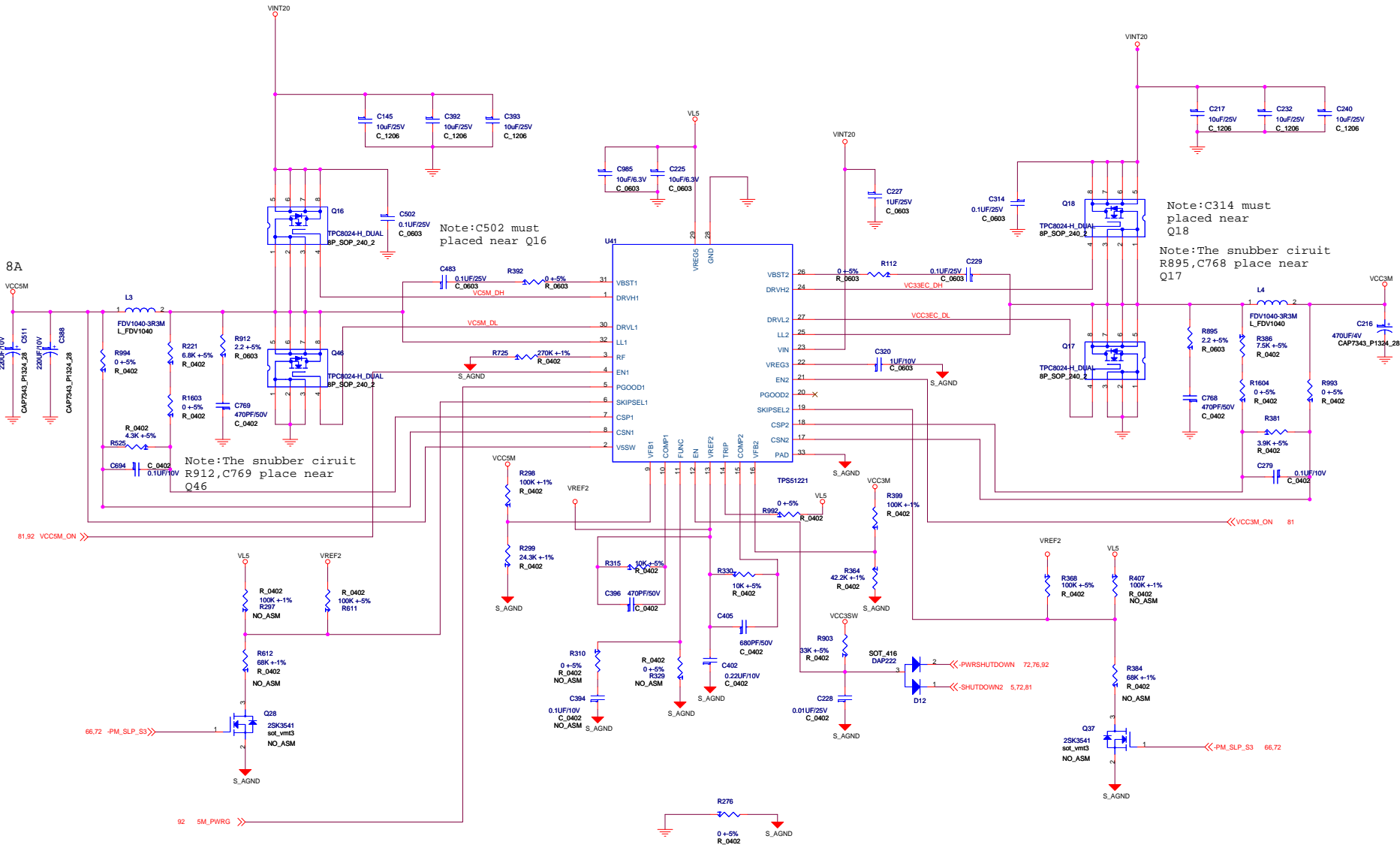

Note:C502 must placed near Q16

Note:C314 must placed near Q18
Note:The snubber circuit R895,C768 place near Q17

Note:The snubber circuit R912,C769 place near Q46

Note:R10029 must be placed near U41.28 PIN(GND)

笔记本维修资料 <http://shop36609371.taobao.com>

QQ:52643956

DESIGNER	<OrgAddr1>	
CHECKED	<OrgAddr2>	
APPROVED	<OrgAddr3>	Part No. 42X7359
CLASS	<OrgAddr4>	EC No. L52888
<small>THIS DOCUMENT IS THE PROPERTY OF LENOVO. ITS USE IS RESTRICTED ONLY FOR REPAIRING TO A REQUEST THE QUOTATION OR FOR THE PERFORMANCE OF WORK FOR LENOVO. ALL QUESTIONS MUST BE REFERRED TO THE LENOVO PURCHASING DEPARTMENT.</small>		TITLE: Kodschi2 Ver:PDV
LENOVO CONFIDENTIAL		VCCSM/VCCSM (MAX8774)
		sheet 82 of 102
		Tuesday, October 30, 2007

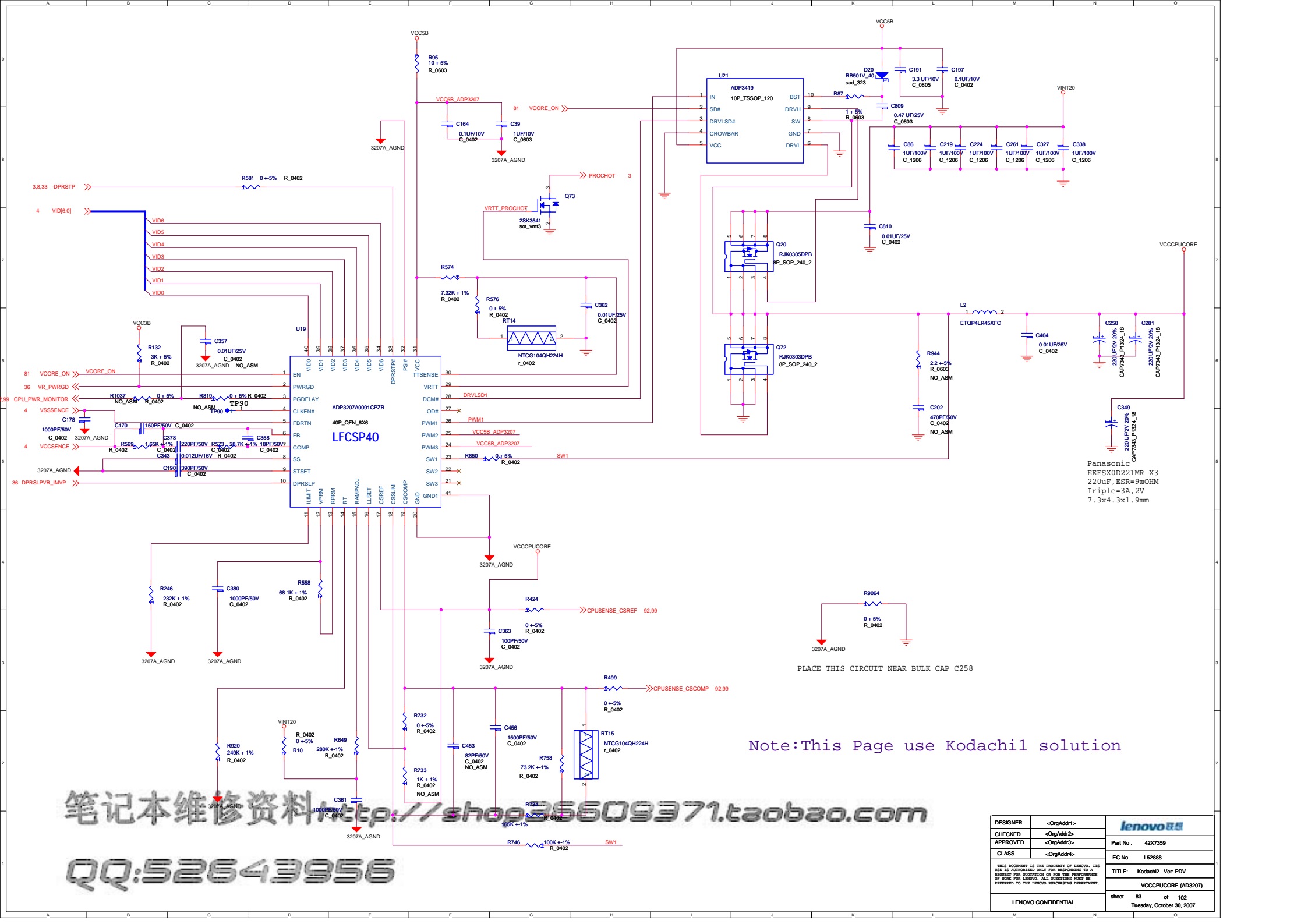

Panasonic
EEFSX0D221MR X3
220uF, ESR=9mOHM
Iripple=3A, 2V
7.3x4.3x1.9mm

PLACE THIS CIRCUIT NEAR BULK CAP C258

Note: This Page use Kodachil solution

笔记本维修资料 <http://shop36509371.taobao.com>
QQ:52643956

DESIGNER	<OrgAddr1>	 Part No. 42X7359 EC No. L52888 TITLE: VCCCPUCORE (AD3207) sheet 83 of 102 Tuesday, October 30, 2007
CHECKED	<OrgAddr2>	
APPROVED	<OrgAddr3>	
CLASS	<OrgAddr4>	
THIS DOCUMENT IS THE PROPERTY OF LENOVO. ITS USE IS AUTHORIZED ONLY FOR REFERRING TO A REQUEST FOR QUOTATION OR FOR THE PERFORMANCE OF WORK FOR LENOVO. ALL QUESTIONS MUST BE REFERRED TO THE LENOVO PURCHASING DEPARTMENT.		
LENOVO CONFIDENTIAL		

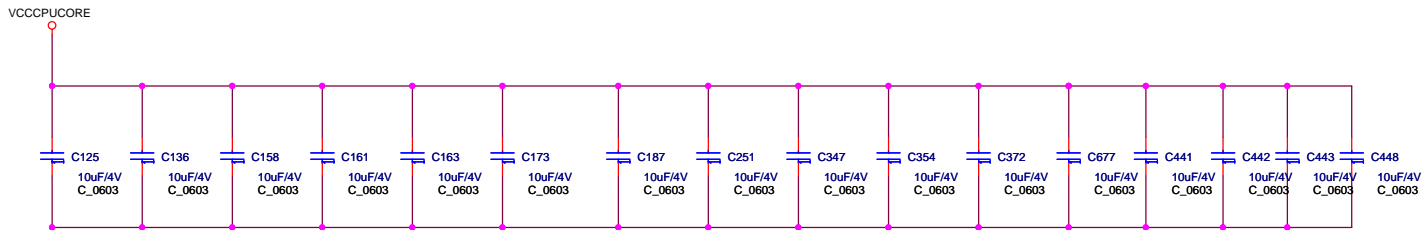

Mid-Frequency Decoupling 10UF 4V X5R 0603 1/16W X 32PCS

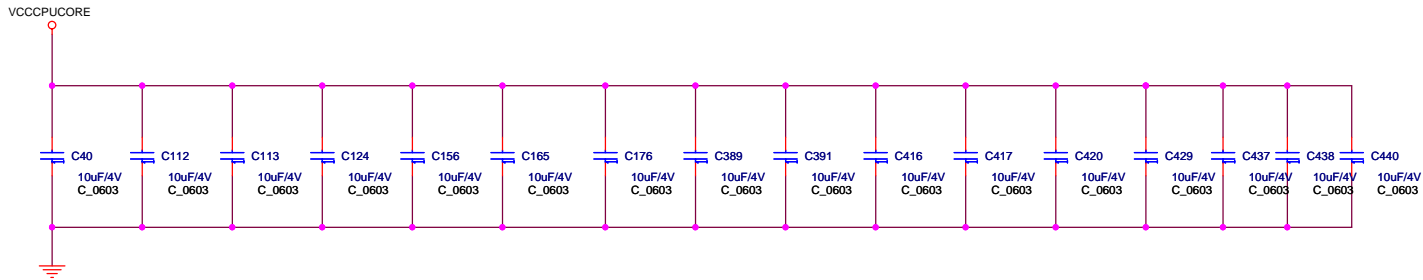

Note: This Page use Kodachil solution

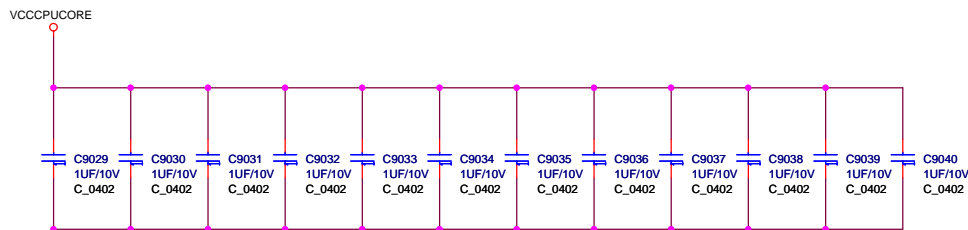

High-Frequency Decoupling 1UF 10V X5R 0402 1/16W X 24PCS

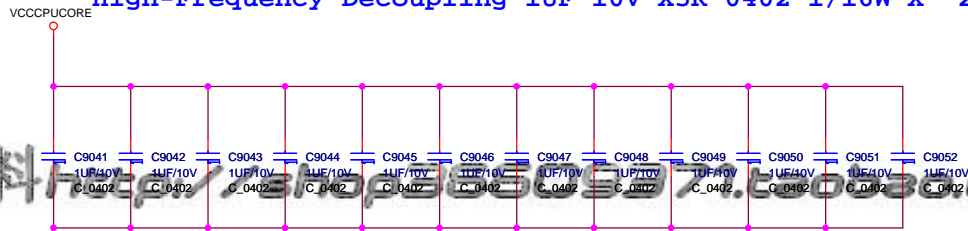

笔记本维修资料 <http://www.52643956.com>
 QQ:52643956

DESIGNER	<OrgAddr1>	
CHECKED	<OrgAddr2>	
APPROVED	<OrgAddr3>	Part No . 42X7359
CLASS	<OrgAddr4>	EC No . L52888
THIS DOCUMENT IS THE PROPERTY OF LENOVO. ITS USE IS AUTHORIZED ONLY FOR RESPONDING TO A REQUEST FOR QUOTATION OR FOR THE PERFORMANCE OF WORK FOR LENOVO. ALL QUESTIONS MUST BE REFERRED TO THE LENOVO PURCHASING DEPARTMENT.		TITLE: Kodachi2 Ver: PDV
LENOVO CONFIDENTIAL		VCCCPUCORE DECOUPLING
		sheet 84 of 102 Tuesday, October 30, 2007

BLANK PAGE

笔记本维修资料 <http://shop36609371.taobao.com>

QQ:52643956

DESIGNER	<OrgAddr1>		
CHECKED	<OrgAddr2>		
APPROVED	<OrgAddr3>		Part No . 42X7359
CLASS	<OrgAddr4>		EC No . L52888
<small>THIS DOCUMENT IS THE PROPERTY OF LENOVO. ITS USE IS AUTHORIZED ONLY FOR RESPONDING TO A REQUEST FOR QUOTATION OR FOR THE PERFORMANCE OF WORK FOR LENOVO. ALL QUESTIONS MUST BE REFERRED TO THE LENOVO PURCHASING DEPARTMENT.</small>		TITLE: Kodachi2 Ver. PDV	
LENOVO CONFIDENTIAL		sheet 85 of 102 Tuesday, October 30, 2007	

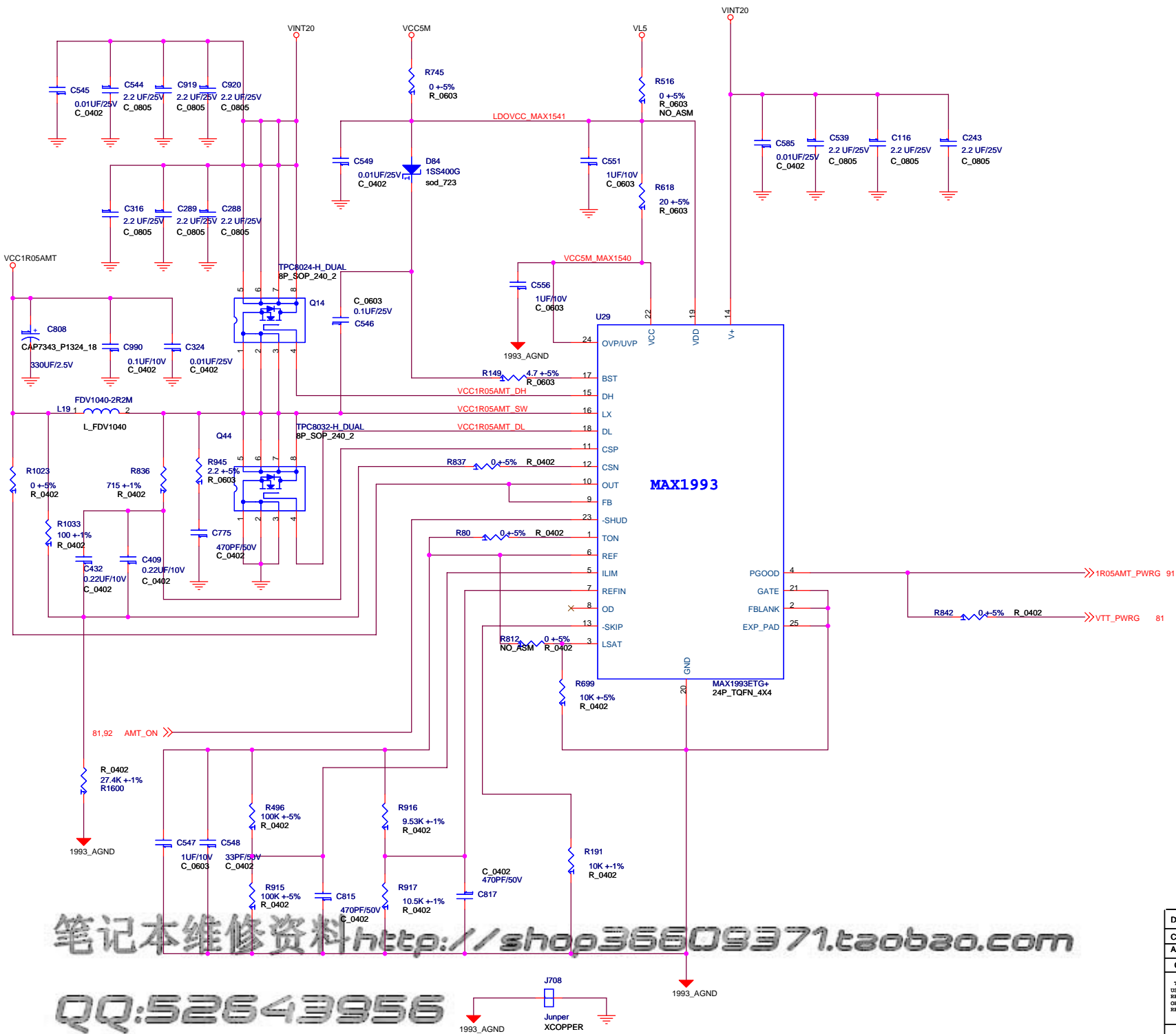

笔记本维修资料 <http://shop36609371.taobao.com>
 QQ:52643956

DESIGNER	<OrgAddr1>	
CHECKED	<OrgAddr2>	
APPROVED	<OrgAddr3>	Part No. 42X7359
CLASS	<OrgAddr4>	EC No. L52888
THIS DOCUMENT IS THE PROPERTY OF LENOVO. ITS USE IS AUTHORIZED ONLY FOR RESPONDING TO A REQUEST FOR QUOTATION OR FOR THE PERFORMANCE OF WORK FOR LENOVO. ALL QUESTIONS MUST BE REFERRED TO THE LENOVO PURCHASING DEPARTMENT.		
TITLE: Kodachi2 Ver: PDV		BLANK
LENOVO CONFIDENTIAL		sheet 87 of 102 Tuesday, October 30, 2007

The expose pad(pin29:GND) must be start-connected to GND (pin24:MAX8632_AGND) and PGND2(pin11).

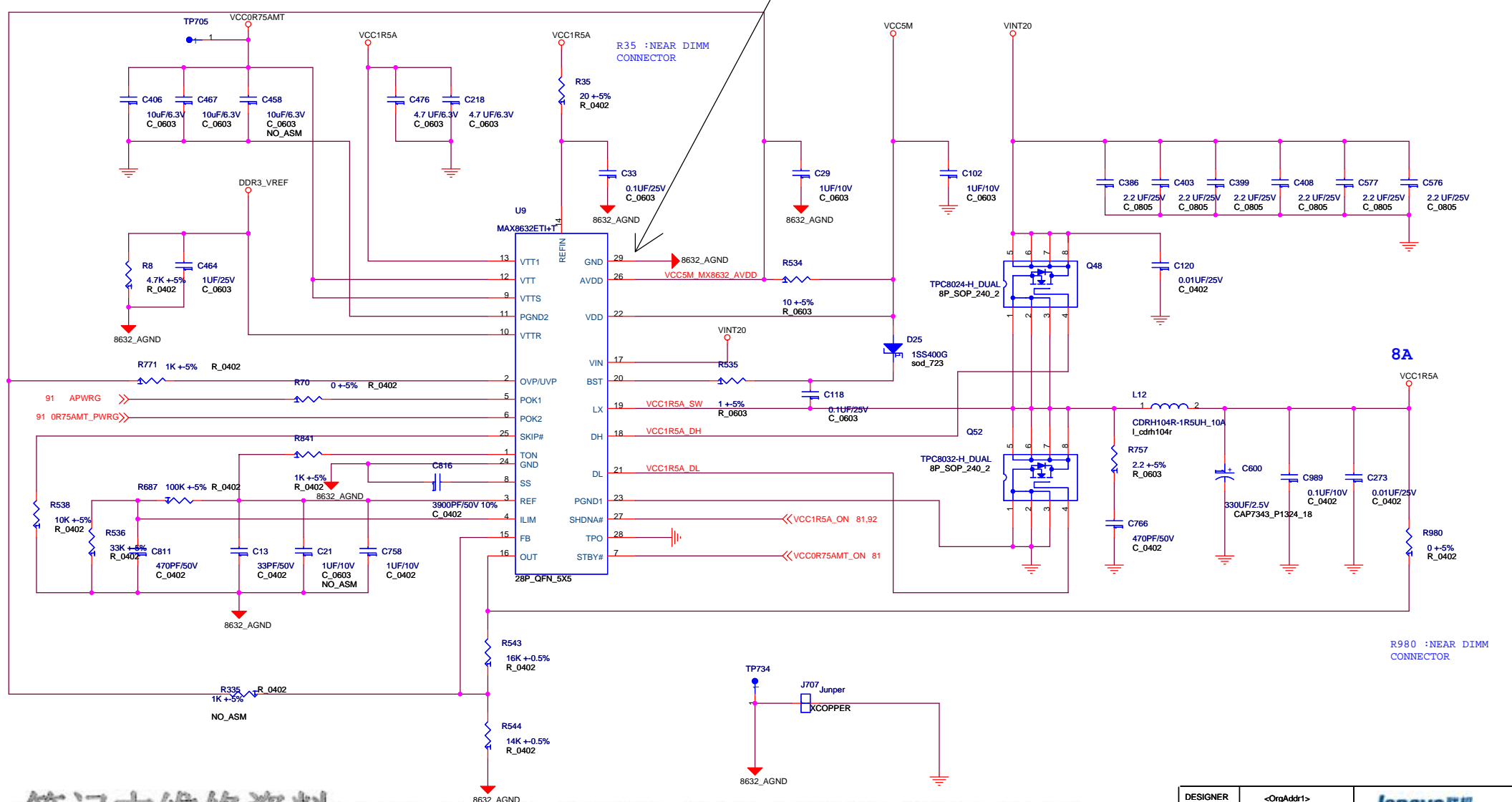

笔记本维修资料 <http://shop36609371.taobao.com>

QQ:52643956

DESIGNER	<OrgAddr1>	 Part No. 42X7359
CHECKED	<OrgAddr2>	
APPROVED	<OrgAddr3>	EC No. L52888
CLASS	<OrgAddr4>	TITLE: Kodachi2 Ver: PDV
THIS DOCUMENT IS THE PROPERTY OF LENOVO. ITS USE IS AUTHORIZED ONLY FOR RESPONDING TO A REQUEST FOR QUOTATION OR FOR THE PERFORMANCE OF WORK FOR LENOVO. ALL QUESTIONS MUST BE REFERRED TO THE LENOVO PURCHASING DEPARTMENT.		VCC1R5A/OR75AMT(MAX8632)
LENOVO CONFIDENTIAL		sheet 88 of 102 Tuesday, October 30, 2007

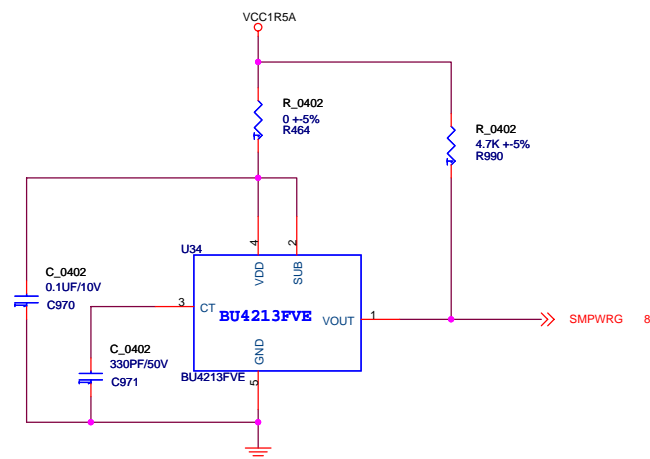

笔记本维修资料 <http://shop36609371.taobao.com>
 QQ:52643956

DESIGNER	<OrgAddr1>	lenovo 联想
CHECKED	<OrgAddr2>	
APPROVED	<OrgAddr3>	Part No . 42X7359
CLASS	<OrgAddr4>	EC No . L52888
THIS DOCUMENT IS THE PROPERTY OF LENOVO. ITS USE IS AUTHORIZED ONLY FOR RESPONDING TO A REQUEST FOR QUOTATION OR FOR THE PERFORMANCE OF WORK FOR LENOVO. ALL QUESTIONS MUST BE REFERRED TO THE LENOVO PURCHASING DEPARTMENT.		TITLE: Kodachi2 Ver: PDV
		LOAD SW 0R75AMT
LENOVO CONFIDENTIAL		sheet 89 of 102 Tuesday, October 30, 2007

BLANK PAGE

笔记本维修资料 <http://shop36609371.taobao.com>

QQ:52643956

DESIGNER	<OrgAddr1>	
CHECKED	<OrgAddr2>	
APPROVED	<OrgAddr3>	
CLASS	<OrgAddr4>	
<small>THIS DOCUMENT IS THE PROPERTY OF LENOVO. ITS USE IS AUTHORIZED ONLY FOR RESPONDING TO A REQUEST FOR QUOTATION OR FOR THE PERFORMANCE OF WORK FOR LENOVO. ALL QUESTIONS MUST BE REFERRED TO THE LENOVO PURCHASING DEPARTMENT.</small>		TITLE: Kodachi2 Ver: PDV
LENOVO CONFIDENTIAL		LOAD SW VIDEO
		sheet 90 of 102 Tuesday, October 30, 2007

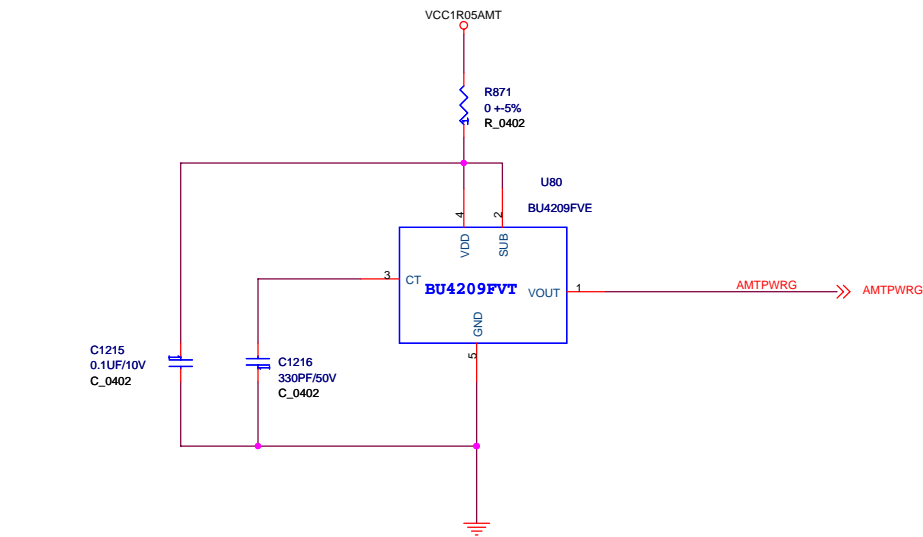

TABLE

	AMT	NO-AMT
U80	ASM	NO_ASM
R871	ASM	NO_ASM
R1215	ASM	NO_ASM
R1216	ASM	NO_ASM

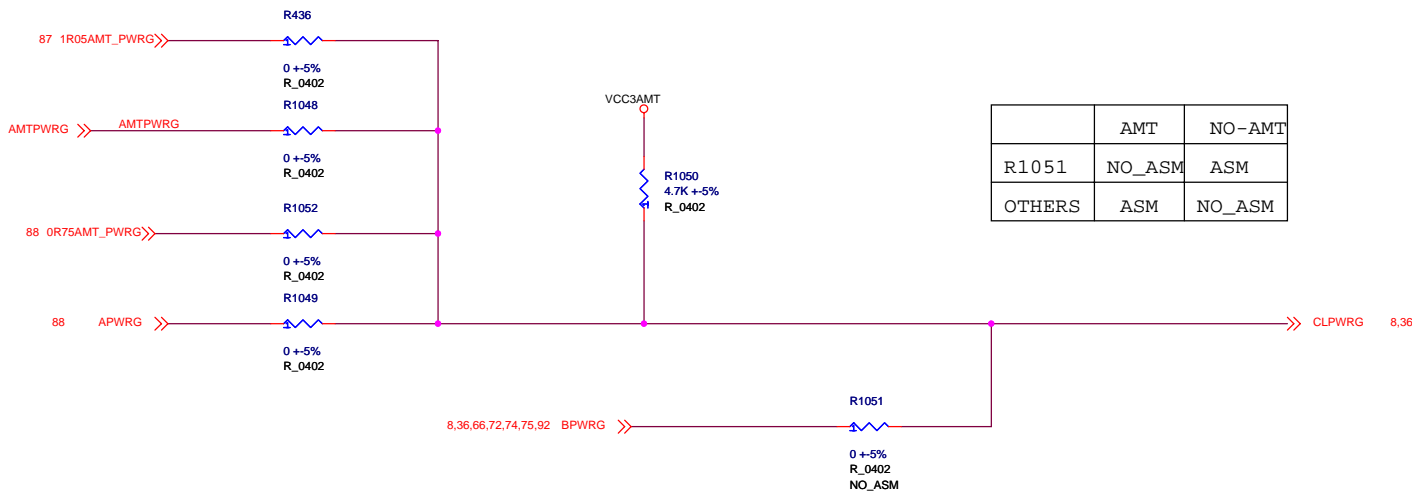

	AMT	NO-AMT
R1051	NO_ASM	ASM
OTHERS	ASM	NO_ASM

笔记本维修资料 <http://shop36609371.taobao.com>
 QQ:52643956

DESIGNER	<OrgAddr1>	lenovo 联想
CHECKED	<OrgAddr2>	
APPROVED	<OrgAddr3>	
CLASS	<OrgAddr4>	
<small>THIS DOCUMENT IS THE PROPERTY OF LENOVO. ITS USE IS AUTHORIZED ONLY FOR RESPONDING TO A REQUEST FOR QUOTATION OR FOR THE PERFORMANCE OF WORK FOR LENOVO. ALL QUESTIONS MUST BE REFERRED TO THE LENOVO PURCHASING DEPARTMENT.</small>		Part No. 42X7359
		EC No. L52888
		TITLE: Kodachi2 Ver: PDV
		CLPWRG
LENOVO CONFIDENTIAL		sheet 91 of 102 Tuesday, October 30, 2007

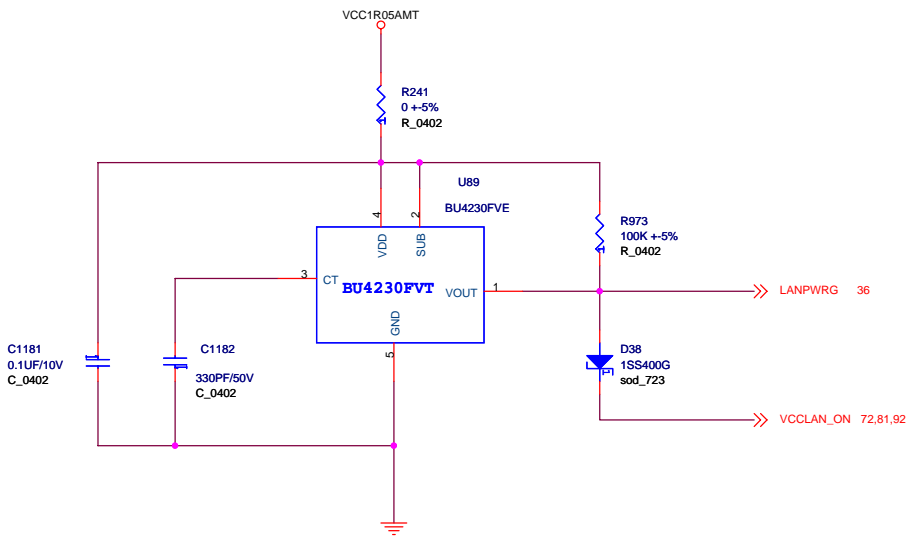

TABLE

AMT	SUPPORT	NON
R1133	NO_ASM	ASM
THE OTHER	ASM	NO_ASM

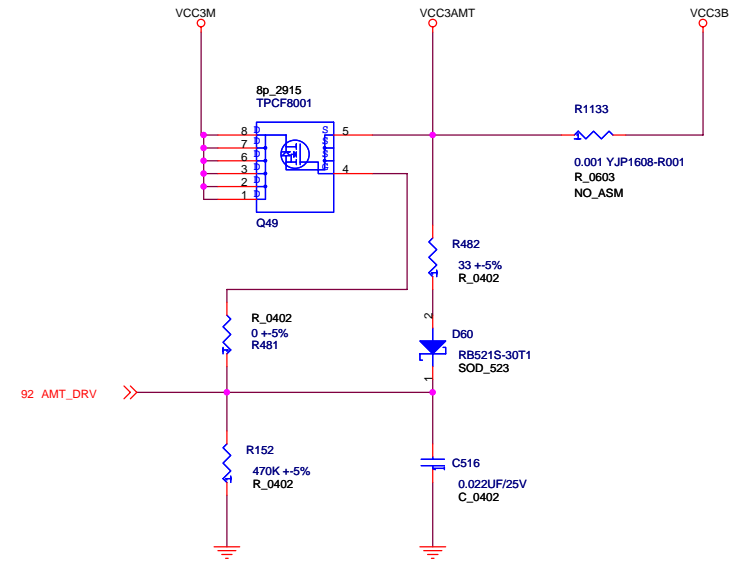
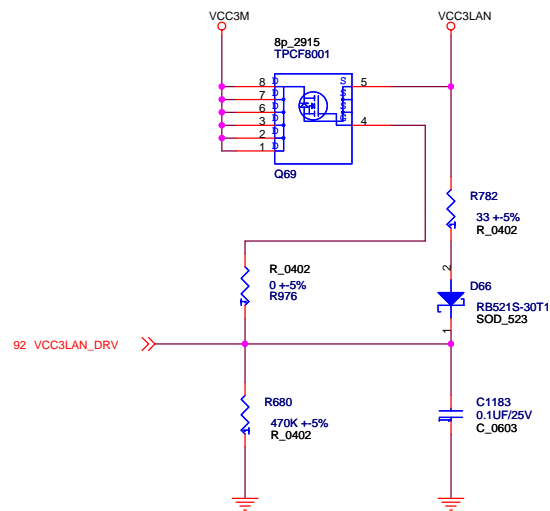

笔记本维修资料 <http://shop36609371.taobao.com>
 QQ:52643956

DESIGNER	<OrgAddr1>	
CHECKED	<OrgAddr2>	
APPROVED	<OrgAddr3>	Part No. 42X7359
CLASS	<OrgAddr4>	EC No. L52888
THIS DOCUMENT IS THE PROPERTY OF LENOVO. ITS USE IS AUTHORIZED ONLY FOR RESPONDING TO A REQUEST FOR QUOTATION OR FOR THE PERFORMANCE OF WORK FOR LENOVO. ALL QUESTIONS MUST BE REFERRED TO THE LENOVO PURCHASING DEPARTMENT.		TITLE: Kodachi2 Ver: PDV
		LOAD SW AMT&LAN
LENOVO CONFIDENTIAL		sheet 93 of 102 Tuesday, October 30, 2007

BLANK PAGE

笔记本维修资料 <http://shop36609371.taobao.com>

QQ:52643956

DESIGNER	<OrgAddr1>		
CHECKED	<OrgAddr2>		
APPROVED	<OrgAddr3>		Part No. 42X7359
CLASS	<OrgAddr4>		EC No. L52888
<small>THIS DOCUMENT IS THE PROPERTY OF LENOVO. ITS USE IS AUTHORIZED ONLY FOR RESPONDING TO A REQUEST FOR QUOTATION OR FOR THE PERFORMANCE OF WORK FOR LENOVO. ALL QUESTIONS MUST BE REFERRED TO THE LENOVO PURCHASING DEPARTMENT.</small>		TITLE: Kodachi2 Ver: PDV	
LENOVO CONFIDENTIAL		LOAD SW VEDIO	
		sheet 94 of 102 Tuesday, October 30, 2007	

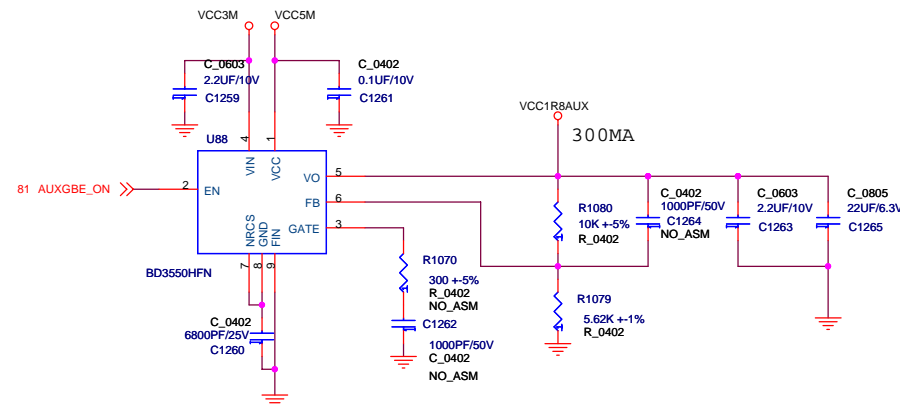

笔记本维修资料 <http://shop36609371.taobao.com>

QQ:52643956

DESIGNER	<OrgAddr1>	 Part No. 42X7359 EC No. L52888 TITLE: Kodachi2 Ver: PDV LOAD SW AUX sheet 95 of 102 Tuesday, October 30, 2007
CHECKED	<OrgAddr2>	
APPROVED	<OrgAddr3>	
CLASS	<OrgAddr4>	
<small>THIS DOCUMENT IS THE PROPERTY OF LENOVO. ITS USE IS AUTHORIZED ONLY FOR RESPONDING TO A REQUEST FOR QUOTATION OR FOR THE PERFORMANCE OF WORK FOR LENOVO. ALL QUESTIONS MUST BE REFERRED TO THE LENOVO PURCHASING DEPARTMENT.</small>		
LENOVO CONFIDENTIAL		

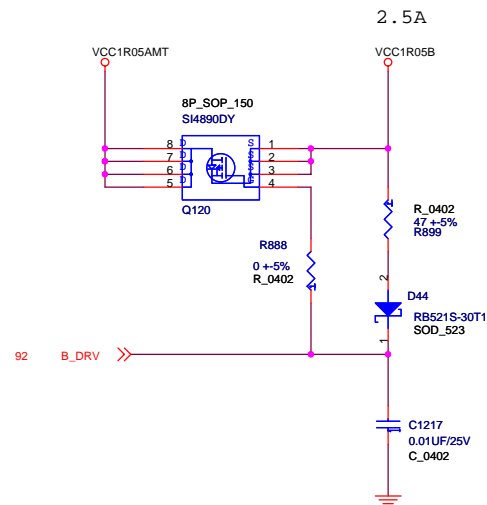
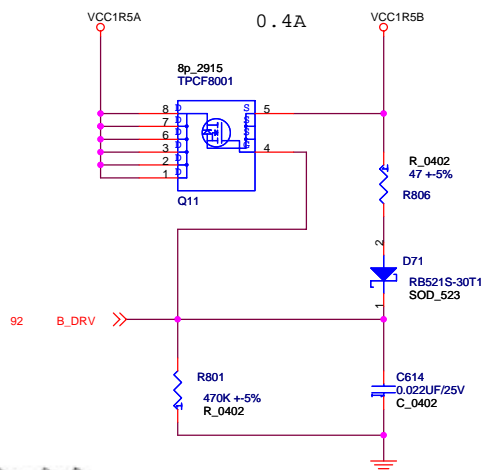
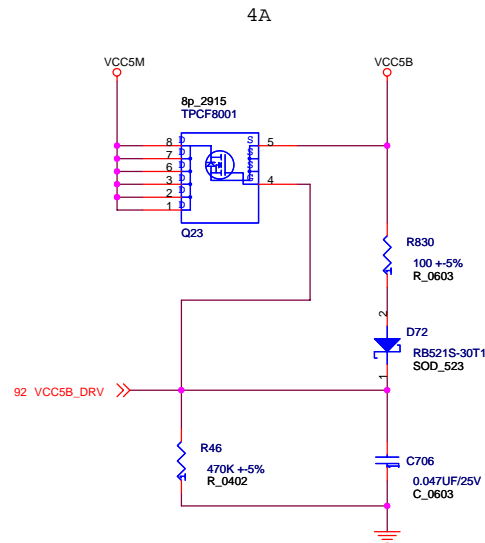
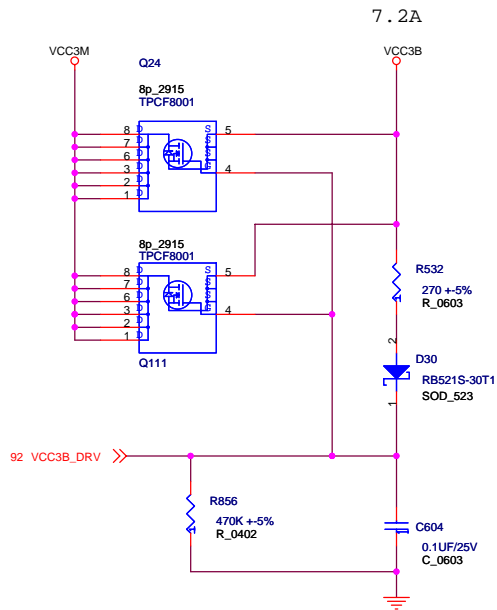

笔记本维修资料 <http://shop36609371.taobao.com>

QQ:52643956

DESIGNER	<OrgAddr1>	
CHECKED	<OrgAddr2>	
APPROVED	<OrgAddr3>	Part No. 42X7359
CLASS	<OrgAddr4>	EC No. L52888
THIS DOCUMENT IS THE PROPERTY OF LENOVO. ITS USE IS AUTHORIZED ONLY FOR RESPONDING TO A REQUEST FOR QUOTATION OR FOR THE PERFORMANCE OF WORK FOR LENOVO. ALL QUESTIONS MUST BE REFERRED TO THE LENOVO PURCHASING DEPARTMENT.		TITLE: Kodachi2 Ver: PDV
		LOAD SW B
LENOVO CONFIDENTIAL		sheet 96 of 102 Tuesday, October 30, 2007

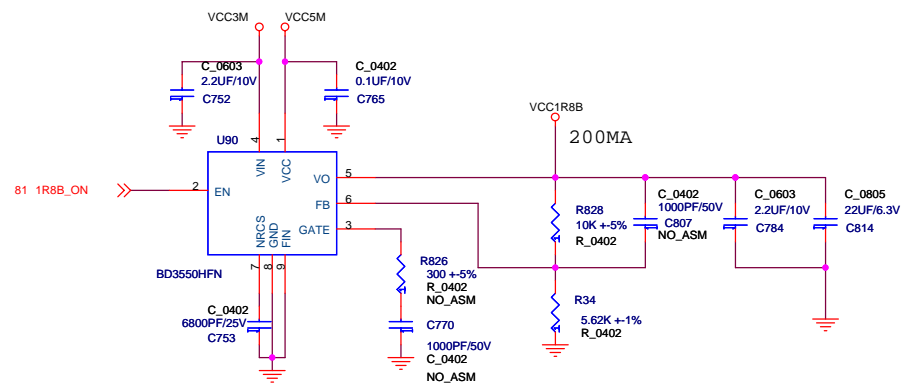

笔记本维修资料 <http://shop36609371.taobao.com>

QQ:52643956

DESIGNER	<OrgAddr1>	 Part No . 42X7359 EC No . L52888 TITLE: Kodachi2 Ver: PDV DC/DC VCC1R8B sheet 97 of 102 Tuesday, October 30, 2007
CHECKED	<OrgAddr2>	
APPROVED	<OrgAddr3>	
CLASS	<OrgAddr4>	
<small>THIS DOCUMENT IS THE PROPERTY OF LENOVO. ITS USE IS AUTHORIZED ONLY FOR RESPONDING TO A REQUEST FOR QUOTATION OR FOR THE PERFORMANCE OF WORK FOR LENOVO. ALL QUESTIONS MUST BE REFERRED TO THE LENOVO PURCHASING DEPARTMENT.</small>		
LENOVO CONFIDENTIAL		

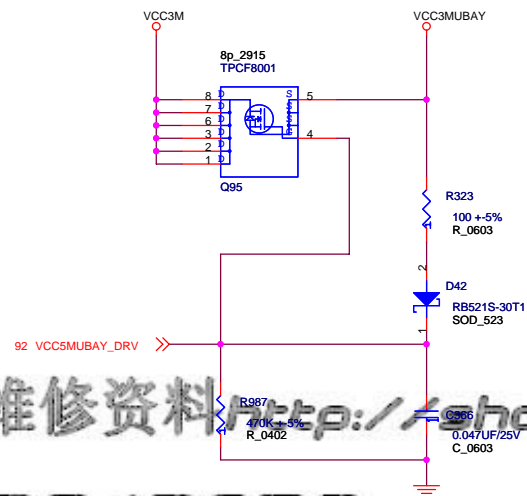
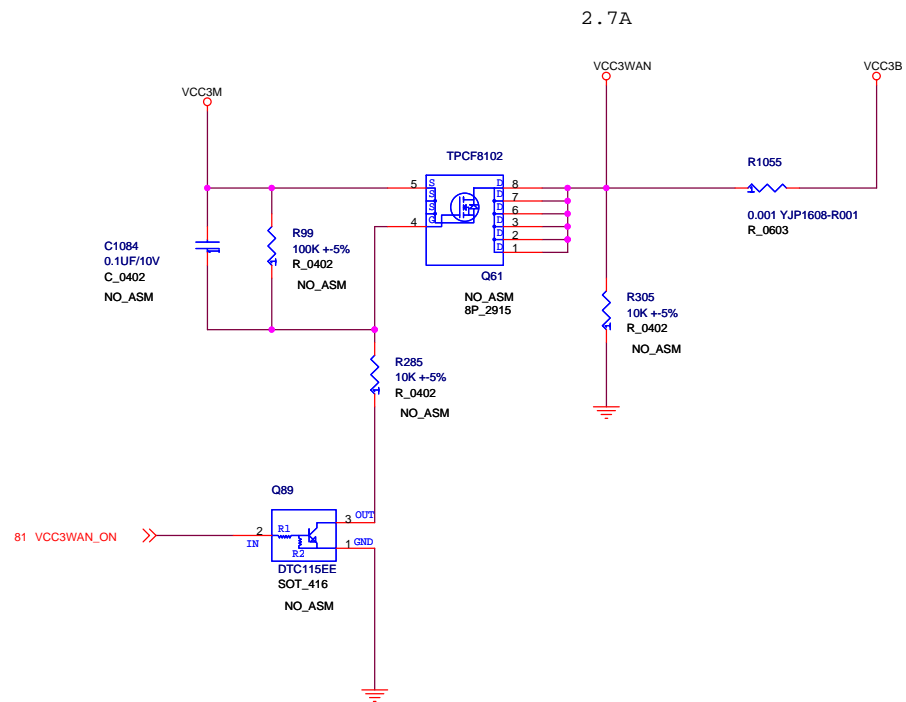
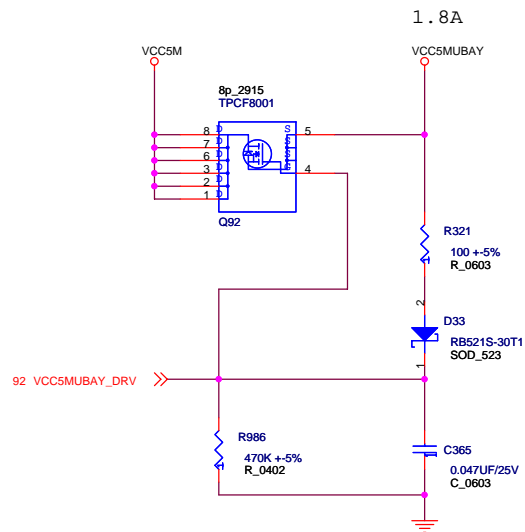

笔记本维修资料 <http://shop36609371.taobao.com>
 QQ:52643956

DESIGNER	<OrgAddr1>	
CHECKED	<OrgAddr2>	
APPROVED	<OrgAddr3>	Part No. 42X7359
CLASS	<OrgAddr4>	EC No. L52888
THIS DOCUMENT IS THE PROPERTY OF LENOVO. ITS USE IS AUTHORIZED ONLY FOR RESPONDING TO A REQUEST FOR QUOTATION OR FOR THE PERFORMANCE OF WORK FOR LENOVO. ALL QUESTIONS MUST BE REFERRED TO THE LENOVO PURCHASING DEPARTMENT.		TITLE: Kodachi2 Ver: PDV
		LOAD SW UBAY&WWAN
LENOVO CONFIDENTIAL		sheet 98 of 102 Tuesday, October 30, 2007

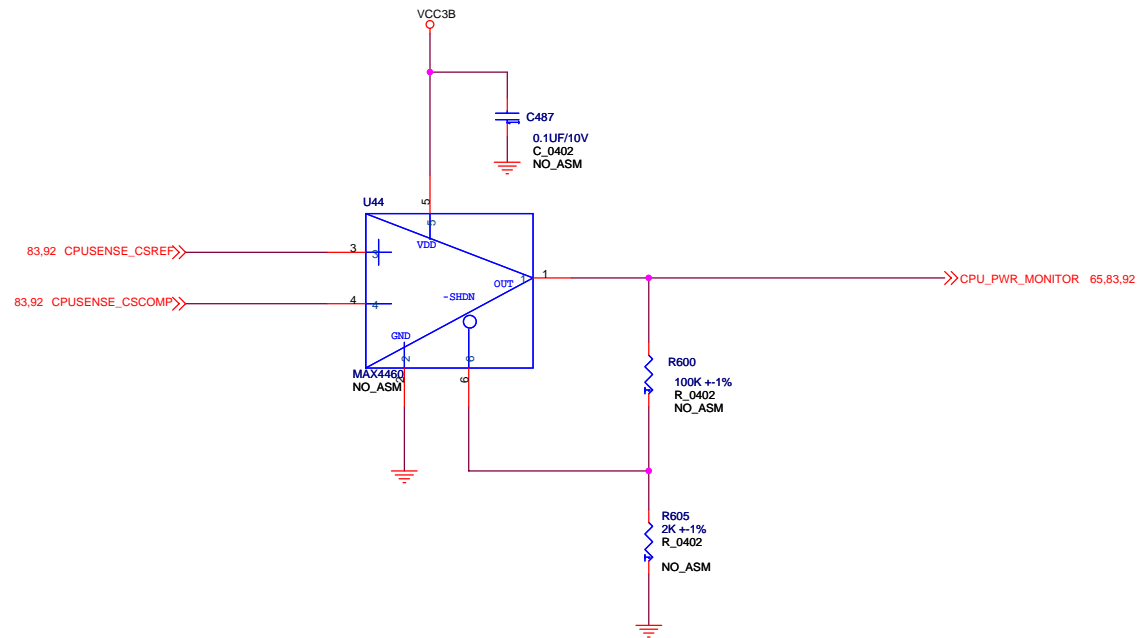

笔记本维修资料 <http://shop36609371.taobao.com>

QQ:52643956

DESIGNER	<OrgAddr1>	lenovo 联想
CHECKED	<OrgAddr2>	
APPROVED	<OrgAddr3>	Part No . 42X7359
CLASS	<OrgAddr4>	EC No . L52888
THIS DOCUMENT IS THE PROPERTY OF LENOVO. ITS USE IS AUTHORIZED ONLY FOR RESPONDING TO A REQUEST FOR QUOTATION OR FOR THE PERFORMANCE OF WORK FOR LENOVO. ALL QUESTIONS MUST BE REFERRED TO THE LENOVO PURCHASING DEPARTMENT.		TITLE: Kodachi2 Ver: PDV
		CPU POWER MONITOR
LENOVO CONFIDENTIAL		sheet 99 of 102 Tuesday, October 30, 2007

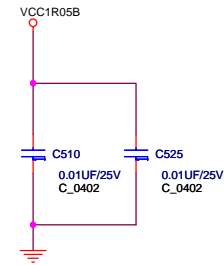
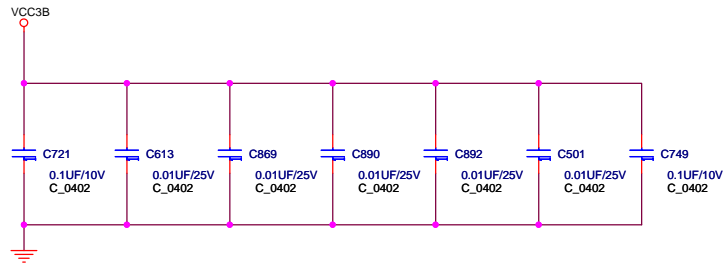
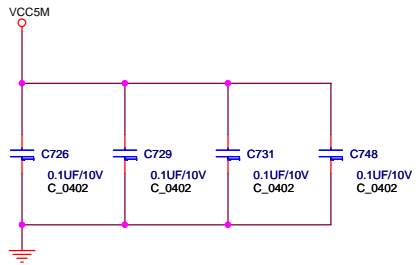
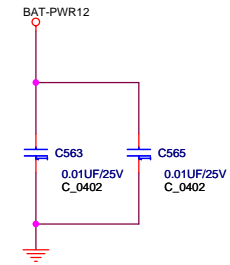
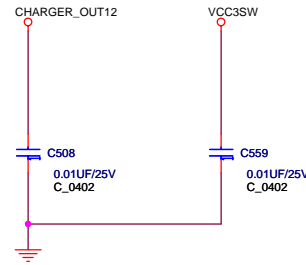
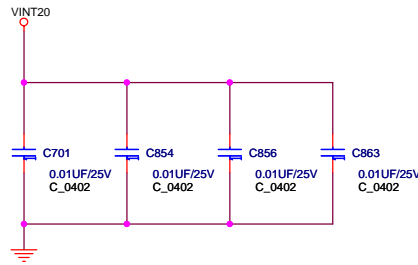
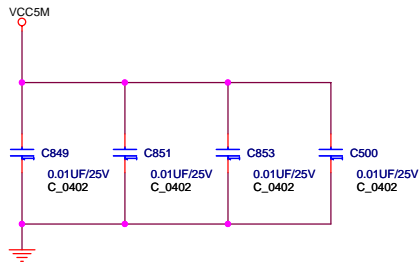
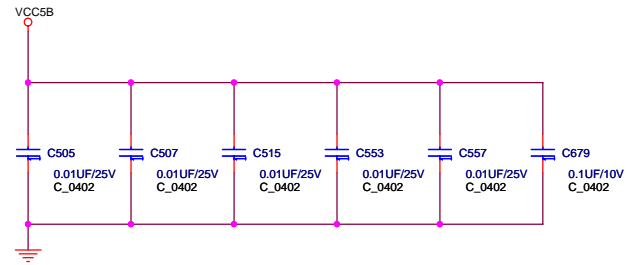
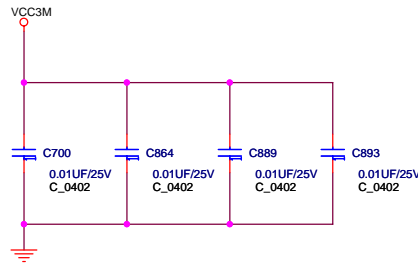
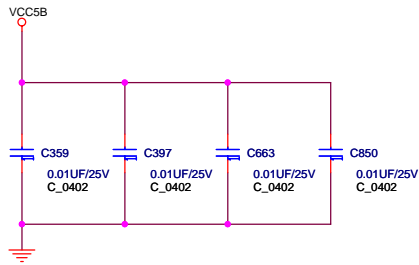

笔记本维修资料 <http://shop36609371.taobao.com>
 QQ:52643956

DESIGNER	<OrgAddr1>	
CHECKED	<OrgAddr2>	
APPROVED	<OrgAddr3>	Part No. 42X7359
CLASS	<OrgAddr4>	EC No. L52888
THIS DOCUMENT IS THE PROPERTY OF LENOVO. ITS USE IS AUTHORIZED ONLY FOR RESPONDING TO A REQUEST FOR QUOTATION OR FOR THE PERFORMANCE OF WORK FOR LENOVO. ALL QUESTIONS MUST BE REFERRED TO THE LENOVO PURCHASING DEPARTMENT.		TITLE: Kodachi2 Ver: PDV
LENOVO CONFIDENTIAL		EMC DECOUPLING
		sheet 100 of 102 Tuesday, October 30, 2007

PTH FOR SCREW HOLE

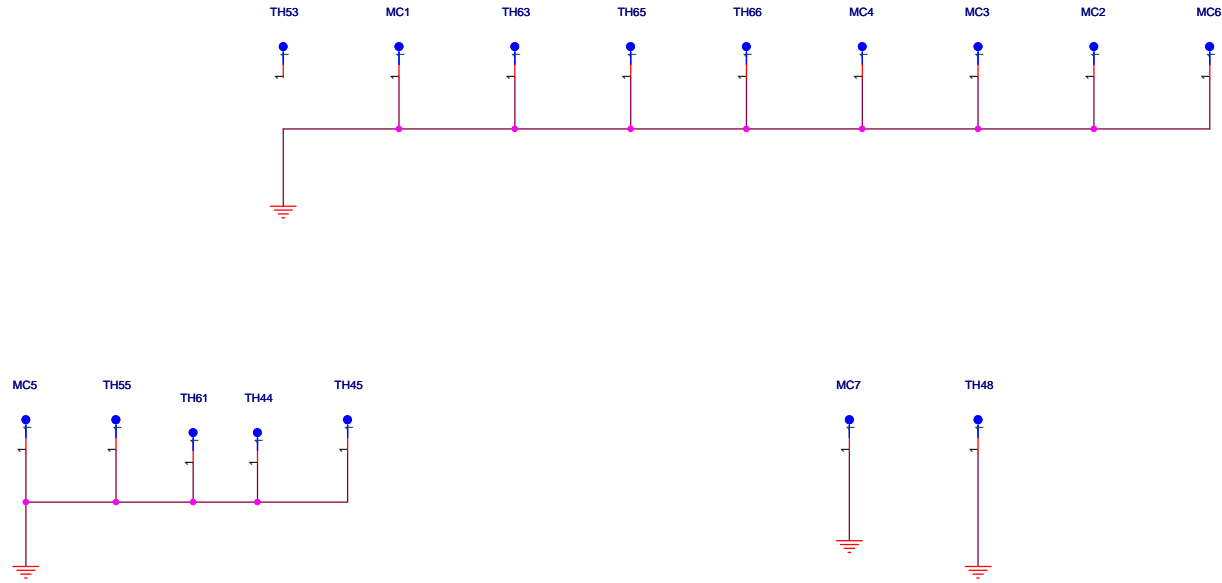
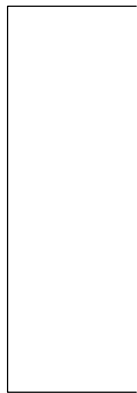

笔记本维修资料 <http://shop36609371.taobao.com>
 QQ:52643956

DESIGNER	<OrgAddr1>	lenovo 联想
CHECKED	<OrgAddr2>	
APPROVED	<OrgAddr3>	Part No . 42X7359
CLASS	<OrgAddr4>	EC No . L52888
<small>THIS DOCUMENT IS THE PROPERTY OF LENOVO. ITS USE IS AUTHORIZED ONLY FOR RESPONDING TO A REQUEST FOR QUOTATION OR FOR THE PERFORMANCE OF WORK FOR LENOVO. ALL QUESTIONS MUST BE REFERRED TO THE LENOVO PURCHASING DEPARTMENT.</small>		TITLE: Kodachi2 Ver: PDV
LENOVO CONFIDENTIAL		PTH SCREW HOLES
		sheet 101 of 102 Tuesday, October 30, 2007

KODACHI2 EC History List

Pre DV phase--->

Ver.1.00	20070822	APPLIED	KODACHI2_SDV_EC	001-004
Ver.1.01	20070906	APPLIED	KODACHI2_SDV_EC	005-009
Ver.1.02	20070915	APPLIED	KODACHI2_SDV_EC	010-020
Ver.1.03	20070918	APPLIED	KODACHI2_SDV_EC	021-027
Ver.1.04	20070920	APPLIED	KODACHI2_SDV_EC	028-031
Ver.1.05	20070921	APPLIED	KODACHI2_SDV_EC	032-035
Ver.1.06	20070924	APPLIED	KODACHI2_SDV_EC	036-039
Ver.1.07	20070924	APPLIED	KODACHI2_SDV_EC	040-044
Ver.1.08	20071009	APPLIED	KODACHI2_SDV_EC	045-055
Ver.1.09	20071017	APPLIED	KODACHI2_SDV_EC	056-065
Ver.1.10	20071019	APPLIED	KODACHI2_SDV_EC	066-077
Ver.1.11	20071024	APPLIED	KODACHI2_SDV_EC	078-086

笔记本维修资料 <http://shop36609371.taobao.com>

QQ:52643956

DESIGNER	<OrgAddr1>	
CHECKED	<OrgAddr2>	
APPROVED	<OrgAddr3>	Part No . 42X7359
CLASS	<OrgAddr4>	EC No . L52888
<small>THIS DOCUMENT IS THE PROPERTY OF LENOVO. ITS USE IS AUTHORIZED ONLY FOR RESPONDING TO A REQUEST FOR QUOTATION OR FOR THE PERFORMANCE OF WORK FOR LENOVO. ALL QUESTIONS MUST BE REFERRED TO THE LENOVO PURCHASING DEPARTMENT.</small>		TITLE: Kodachi2 Ver: PDV
		BLANK
LENOVO CONFIDENTIAL		sheet 102 of 102 Tuesday, October 30, 2007